

**Dinah Zike's  
High School World History  
Reading and Study Skills**

**FOLDABLES™**



**Glencoe**

New York, New York   Columbus, Ohio   Chicago, Illinois   Peoria, Illinois   Woodland Hills, California



The McGraw-Hill Companies

Copyright © by The McGraw-Hill Companies, Inc. All rights reserved. Permission is granted to reproduce the material contained herein on the condition that such material be reproduced only for classroom use; be provided to students, teachers, and families without charge; and be used solely in conjunction with *Glencoe World History texts*. Any other reproduction, for use or sale, is prohibited without prior written permission of the publisher.

Send all inquiries to:  
Glencoe/McGraw-Hill  
8787 Orion Place  
Columbus, OH 43240-4027

ISBN 0-07-865362-2

Printed in the United States of America

1 2 3 4 5 6 7 8 9 10 024 08 07 06 05 04

# Table of Contents

Letter From Dinah Zike ..... 1

## Introduction to Foldables

Why Use Foldables in Social Studies? ..... 2  
Foldable Basics ..... 3



## Folding Instructions

Basic Foldable Shapes ..... 5	Four-Door Book ..... 23
Half-Book ..... 6	Envelope Fold ..... 24
Folded Book ..... 7	Layered-Look Book ..... 25
Three-Quarter Book ..... 8	Top-Tab Book ..... 26
Bound Book ..... 9	Folding a Circle into Tenths ..... 28
Picture-Frame Book ..... 10	Circle Graph ..... 29
Two-Tab Book ..... 11	Folding into Fifths ..... 30
Pocket Book ..... 12	Folded Table or Chart ..... 31
Matchbook ..... 13	Accordion Book ..... 32
Shutter Fold ..... 14	Pop-Up Book ..... 33
Forward-Backward Book ..... 15	Four-Door Diorama ..... 34
Three-Tab Book ..... 16	Concept-Map Book ..... 35
Three-Tab Book Variations ..... 17	Project Board with Tabs ..... 36
Pyramid Fold ..... 18	Billboard Project ..... 37
Trifold Book ..... 19	Vocabulary Book ..... 38
Three-Pocket Book ..... 20	Sentence Strips ..... 39
Four-Tab Book ..... 21	Sentence-Strip Holder ..... 40
Standing Cube ..... 22	

<b>Topic-Specific Foldables</b> .....	41
<b>Topic 1</b> Early Humans and the Rise of Civilization .....	43
<b>Topic 2</b> Mesopotamian and Egyptian Civilizations .....	44
<b>Topic 3</b> Early India and China .....	45
<b>Topic 4</b> Ancient Greece .....	46
<b>Topic 5</b> Rome and the Rise of Christianity .....	47
<b>Topic 6</b> The World of Islam .....	48
<b>Topic 7</b> Early African Civilizations .....	49
<b>Topic 8</b> The Asian World 400–1500 .....	50
<b>Topic 9</b> Emerging Europe and the Byzantine Empire .....	51
<b>Topic 10</b> Medieval Europe .....	52
<b>Topic 11</b> The Americas, 400–1500 .....	53
<b>Topic 12</b> Renaissance and Reformation, 1350–1600 .....	54
<b>Topic 13</b> The Age of Exploration, 1500–1800 .....	55
<b>Topic 14</b> Crisis and Absolutism in Europe, 1550–1715 .....	56
<b>Topic 15</b> The Muslim Empires, 1450–1800 .....	57
<b>Topic 16</b> The East Asian World, 1400–1800 .....	58
<b>Topic 17</b> Revolution and Enlightenment .....	59
<b>Topic 18</b> French Revolution and Napoleon .....	60
<b>Topic 19</b> Industrialization and Nationalism .....	61
<b>Topic 20</b> Mass Society and Democracy .....	62
<b>Topic 21</b> The Height of Imperialism, 1800–1914 .....	63
<b>Topic 22</b> East Asia Under Challenge .....	64
<b>Topic 23</b> War and Revolution, 1914–1919 .....	65
<b>Topic 24</b> The West Between the Wars .....	66
<b>Topic 25</b> Nationalism Around the World .....	67
<b>Topic 26</b> World War II .....	68
<b>Topic 27</b> Cold War and Postwar Changes .....	69
<b>Topic 28</b> Contemporary Western World, 1970 to the Present .....	70
<b>Topic 29</b> Latin America, 1945 to the Present .....	71
<b>Topic 30</b> Africa and the Middle East, 1945 to the Present .....	72
<b>Topic 31</b> Asia and the Pacific, 1945 to the Present .....	73
<b>Topic 32</b> Challenges and Hopes for the Future .....	74

# Dear Teacher,

## **What's a Foldable?**

A Foldable is a three-dimensional, student-made, interactive graphic organizer based upon a skill. Making a Foldable gives students a fast, kinesthetic activity that helps them organize and retain information. Every chapter in the Teacher Wraparound Edition begins with a note to use a Foldable as a study organizer. Each chapter's Foldable topic in this booklet is designed to be used as a study guide for the main ideas and key points presented in sections of the chapter. Foldables can also be used for a more in-depth investigation of a concept, idea, opinion, event, person, or place studied in a chapter. The purpose of this ancillary is to show you how to create various types of Foldables and provide chapter-specific Foldables examples. With this information, you can individualize Foldables to meet your curriculum needs.



This book is divided into two sections. The first section presents step-by-step instructions, illustrations, and photographs of 34 Foldables. I've included over 100 photographs to help you visualize ways in which they might enhance instruction. The second section presents ideas on how to use Foldables for each chapter in the textbook. You can use the instruction section to design your own Foldables or alter the Foldables presented in each chapter. I suggest making this book available as a resource for students who wish to learn new and creative ways to make study guides, present projects, or do extra-credit work.

## **Who Am I?**

You may have seen Foldables featured in this book used in supplemental programs or staff-development workshops. Today my Foldables are used internationally. I present workshops and keynote addresses to over fifty thousand teachers and parents a year, sharing Foldables that I began inventing, designing, and adapting over thirty-five years ago. Students of all ages are using them for daily work, note-taking activities, student-directed projects, as forms of alternative assessment, journals, graphs, charts, tables, and more.

A handwritten signature in black ink. The signature is written in a cursive style and reads "Dinah Zike". The letters are connected and fluid.

For more information on Foldables, visit <http://www.dinah.com> or call 1-800-99DINAH.

# Why use Foldables in World History?

When teachers ask me why they should take time to use the Foldables featured in this book, I explain that they

- . . . quickly organize, display, and arrange data, making it easier for students to grasp world history concepts, theories, facts, opinions, questions, research, and ideas. They also help sequence events as outlined in the content standards.
- . . . result in student-made study guides that are compiled as students listen for main ideas, read for main ideas, or conduct research.
- . . . provide a multitude of creative formats in which students can present projects, research, interviews, and inquiry-based reports instead of typical poster board formats.
- . . . replace teacher-generated writing or photocopied sheets with student-generated print.
- . . . incorporate the use of such skills as comparing and contrasting, recognizing cause and effect, and finding similarities and differences into daily work and long-term projects. For example, these Foldables can be used to compare and contrast student explanations and/or opinions to those accepted by experts in the field of world history.
- . . . continue to “immerse” students in previously learned vocabulary, concepts, information, generalizations, ideas, and theories, providing them with a strong foundation that they can build upon with new observations, concepts, and knowledge.
- . . . can be used by students or teachers to easily communicate data through graphs, tables, charts, models, and diagrams, including Venn diagrams.
- . . . allow students to make their own journals for recording observations, research information, primary and secondary source data, surveys, and more.
- . . . can be used as alternative assessment tools by teachers to evaluate student progress or by students to evaluate their own progress.
- . . . integrate language arts, science, mathematics and social studies into the study of world history.
- . . . provide a sense of student ownership or investment in the world history curriculum.

# Foldable Basics

## What to Write and Where

Teach students to write general information such as titles, vocabulary words, concepts, questions, main ideas, and dates on the front tabs of their Foldables. This way students can easily recognize main ideas and important concepts. Foldables help students focus on and remember key points without being distracted by other print.

Ask students to write specific information such as supporting ideas, student thoughts, answers to questions, research information, class notes, observations, and definitions under the tabs.

As you teach, demonstrate different ways in which Foldables can be used. Soon you will find that students make their own Foldables and use them independently for study guides and projects.

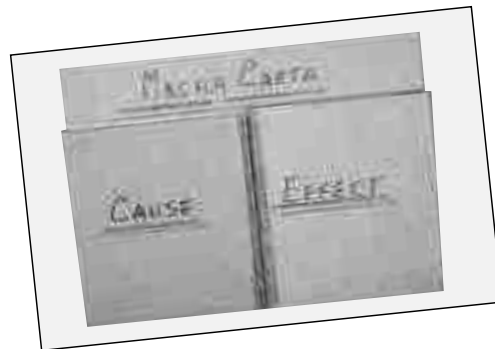

## With or Without Tabs

Foldables with flaps or tabs create study guides that students can use to self check what they know about the general information on the front of tabs. Use Foldables without tabs for assessment purposes or projects where information is presented for others to view quickly.

### Venn Diagram used as a study guide

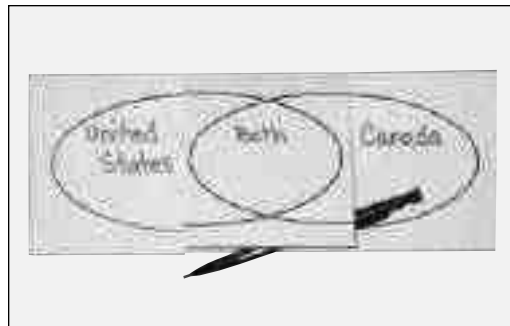

### Venn Diagram used for assessment

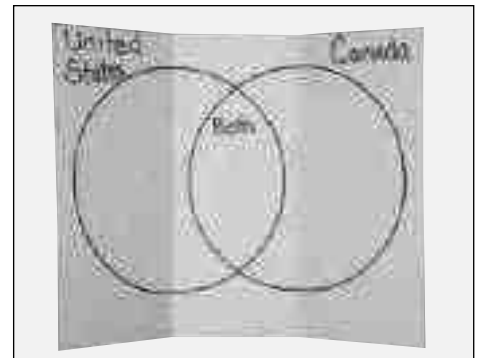

### **What to Do with Scissors and Glue**

If it is difficult for your students to keep glue and scissors at their desks, set up a small table in the classroom and provide several containers of glue, numerous pairs of scissors (sometimes tied to the table), containers of crayons and colored pencils, a stapler, clear tape, and anything else you think students might need to make their Foldables.



### **Storing Foldables**

There are several ways that students can store their Foldables. They can use grocery bags, plastic bags, or shoeboxes. Students can also punch holes in their Foldables and place them in a three-ring binder. Suggest the place strips of two-inch clear tape along one side and punch three holes through the taped edge.

By keeping all of their Foldables together and organized, students will have created their own portfolio.

**HINT:** *I found it more convenient to keep student portfolios in my classroom so student work was always available when needed. Giant laundry-soap boxes make good storage containers for portfolios.*

### **Use This Book As a Creative Resource**

Have this book readily available for students to use as an idea reference for projects, discussions, debates, extra credit work, cooperative learning group presentations, and so on. Encourage students to think of their own versions of Foldables to help them learn the material the best way possible.



# Basic Foldable Shapes

The following figures illustrate the basic folds that are referred to throughout the following section of this book

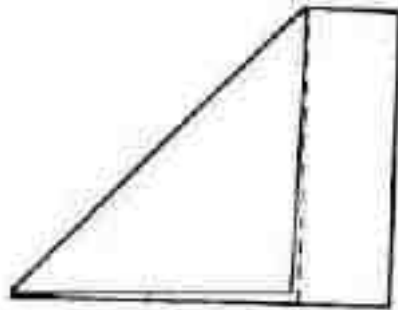

**Taco Fold**

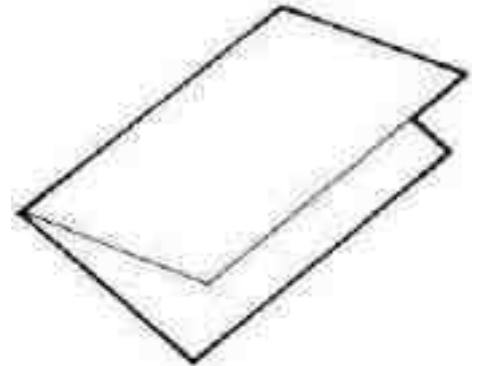

**Hamburger Fold**

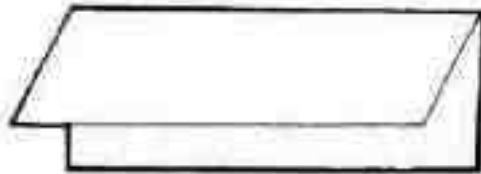

**Hot Dog Fold**

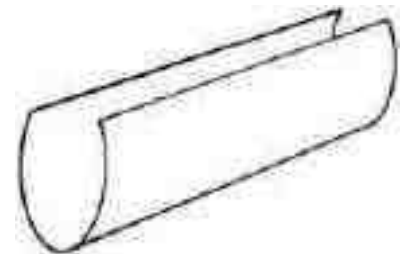

**Burrito Fold**

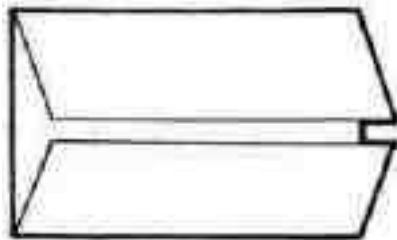

**Shutter Fold**

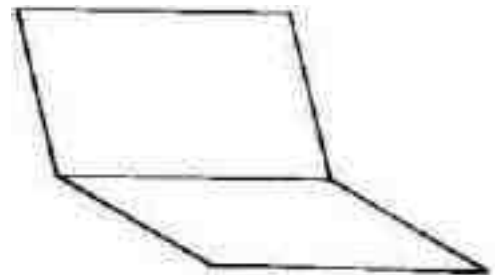

**Valley Fold**

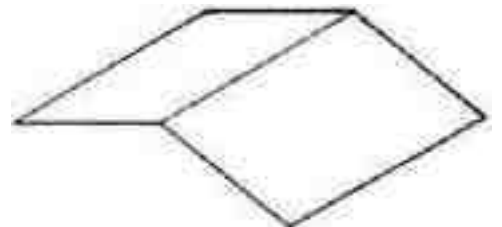

**Mountain Fold**

# Half-Book

Fold a sheet of paper (8 1/2" x 11") in half.

1. This book can be folded vertically like a *hot dog* or . . .
2. . . it can be folded horizontally like a *hamburger*.

Use this book for descriptive, expository, persuasive, or narrative writing, as well as graphs, diagrams, or charts.

1

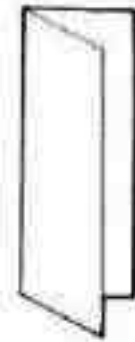

2

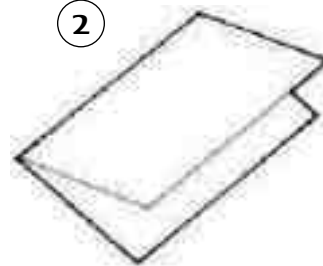

# Folded Book

1. Make a *half-book*.
2. Fold it in half again like a *hamburger*. This makes a ready-made cover, and two small pages for information on the inside.

Use photocopied work sheets, Internet print-outs, and student-drawn diagrams or maps to make this book. If you make the Foldable with a previously graded worksheet, then one sheet of paper will have served for two graded activities.

1



2

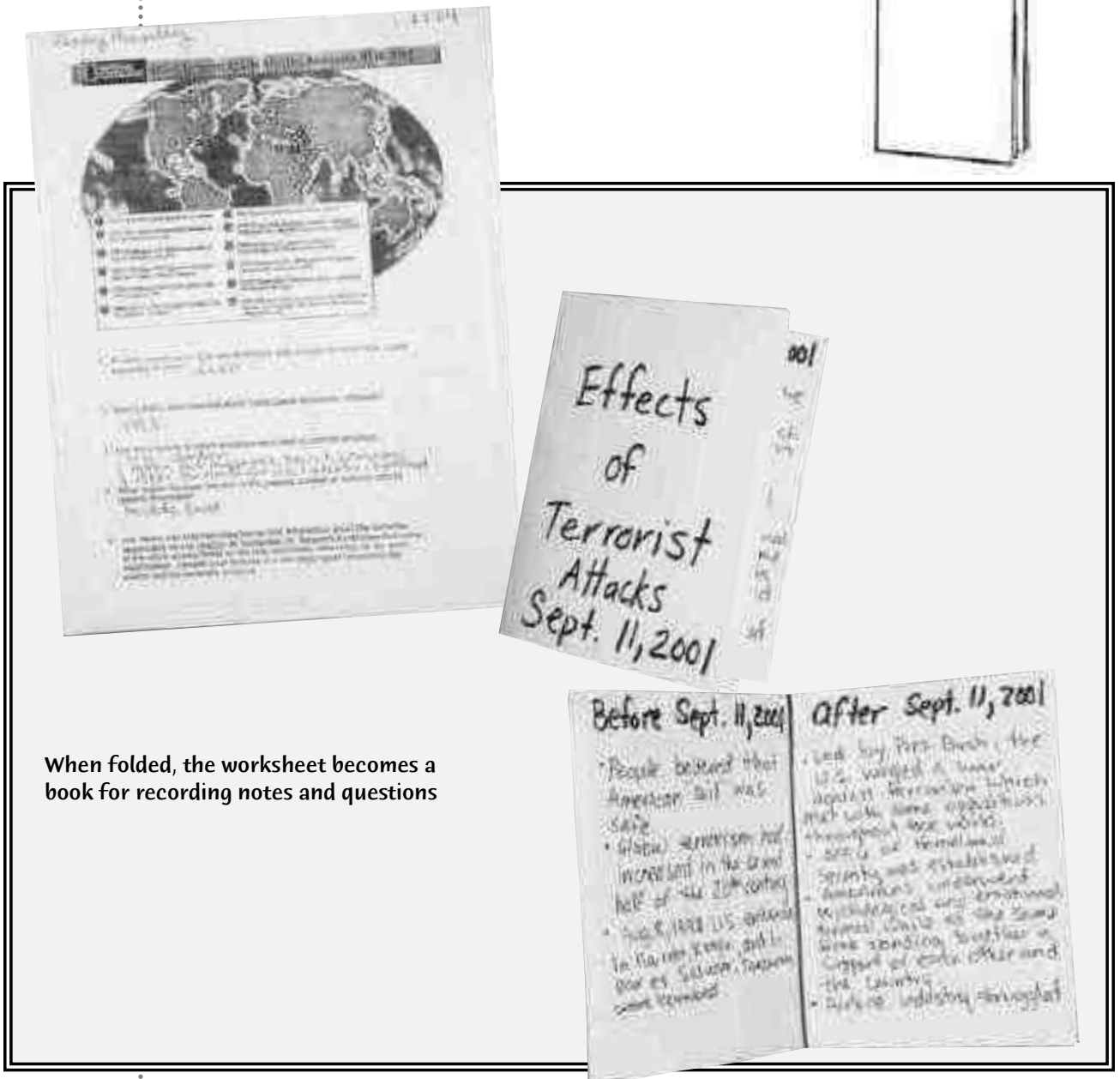

When folded, the worksheet becomes a book for recording notes and questions

Effects  
of  
Terrorist  
Attacks  
Sept. 11, 2001

Before Sept. 11, 2001	After Sept. 11, 2001
<ul style="list-style-type: none"> <li>• People believed that American soil was safe</li> <li>• Global terrorism had increased in the second half of the 20th century</li> <li>• In 1998, US bombed the Al Qaeda base in Sudan, causing some terrorist</li> </ul>	<ul style="list-style-type: none"> <li>• Led by Pres. Bush, the US waged a war against terrorism which had taken some international dimensions</li> <li>• Security was established</li> <li>• American's understand the physical and emotional impact of the Sept. 11 attacks</li> <li>• The industry throughout</li> </ul>

# Three-Quarter Book

1. Take a *two-tab* book and raise the left-hand tab.
2. Cut the tab off at the top fold line.
3. A larger book of information can be made by gluing several *three-quarter books* side-by-side.

Sketch or glue a graphic to the left, write one or more questions on the right, and record answers and information under the right tab.

1

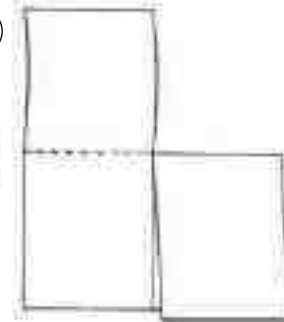

2

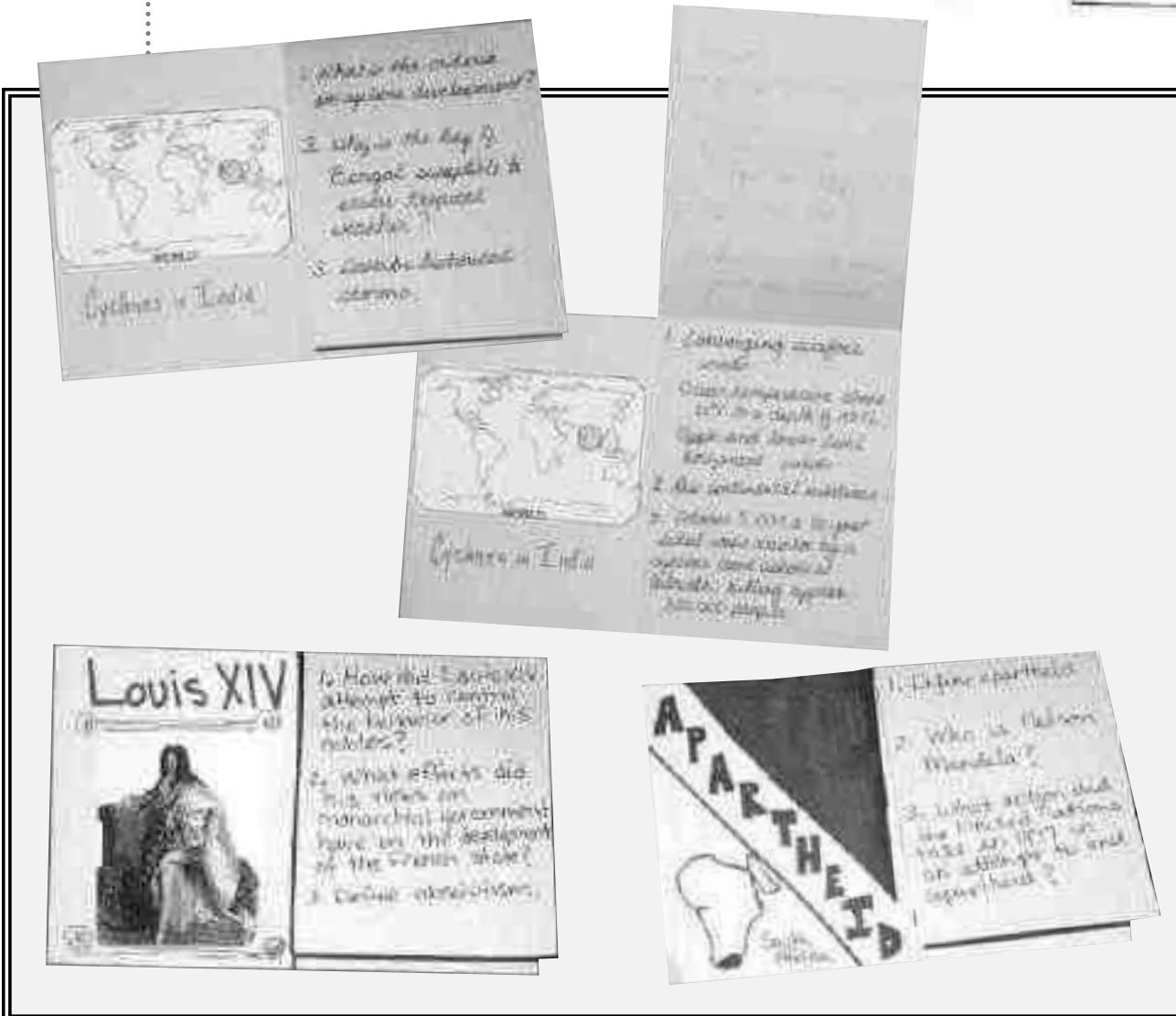
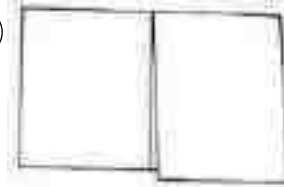

# Bound Book

1. Take two sheets of paper (8 1/2" x 11") and separately fold them like a *hamburger*. Place the papers on top of each other, leaving one sixteenth of an inch between the *mountain tops*.
2. Mark both folds one inch from the outer edges.
3. On one of the folded sheets, cut from the top and bottom edge to the marked spot on both sides.
4. On the second folded sheet, start at one of the marked spots and cut the fold between the two marks.
5. Take the cut sheet from step 3 and fold it like a *burrito*. Place the *burrito* through the other sheet and then open the *burrito*. Fold the bound pages in half to form an eight-page book.

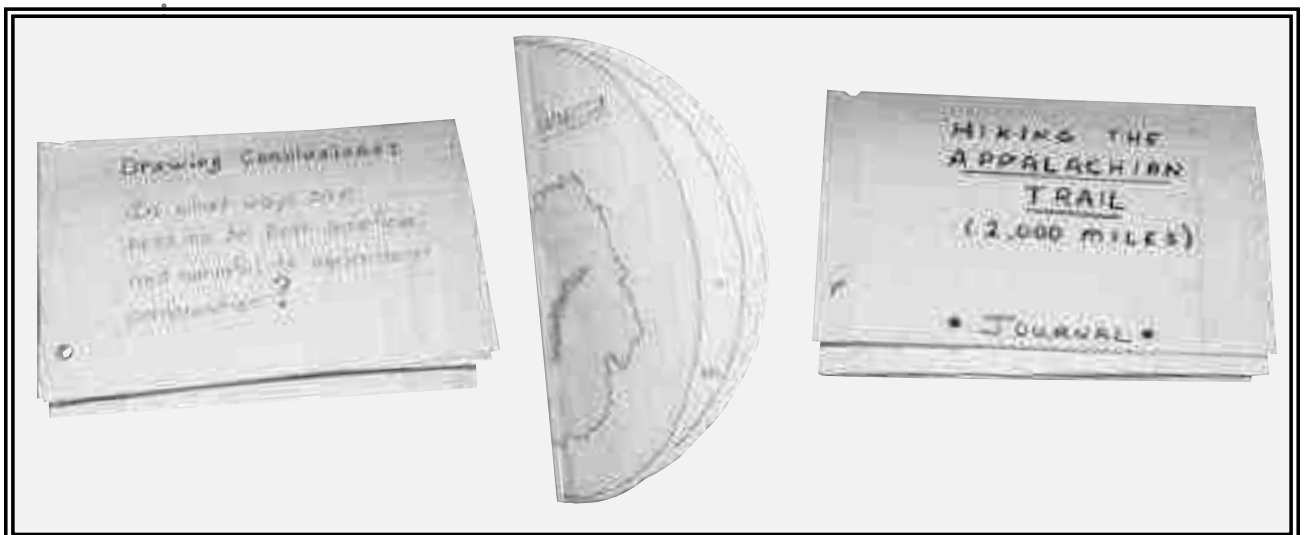
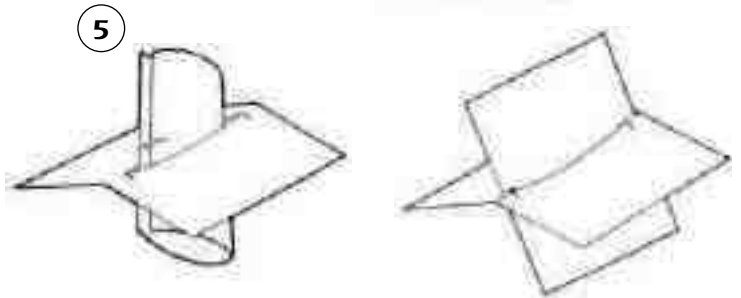
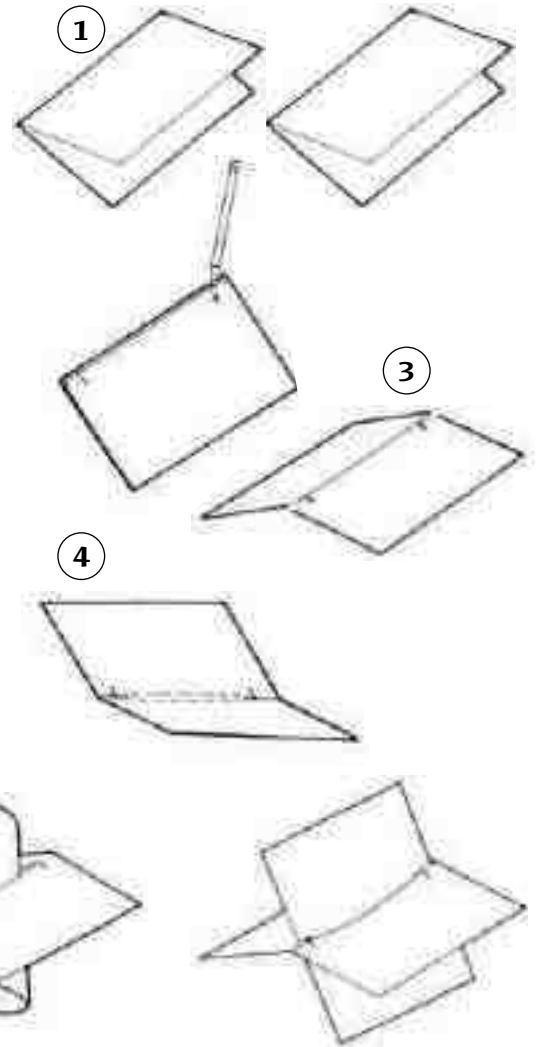

# Picture-Frame Book

1. Fold a sheet of paper (8 1/2" x 11") in half like a *hamburger*.
2. Open the *hamburger* and gently roll one side of the *hamburger* toward the *valley*. Try not to crease the roll.
3. Cut a rectangle out of the middle of the rolled side of the paper leaving a half-inch border, forming a frame.
4. Fold another sheet of paper (8 1/2" x 11") in half like a *hamburger*. Apply glue to the inside border of the picture frame and place the folded, uncut sheet of paper inside.

Use this book to feature a person, place, or thing. Inside the picture frames, glue photographs, magazine pictures, computer-generated graphs, or have students sketch pictures. This book has three inside pages for writing and recording notes.

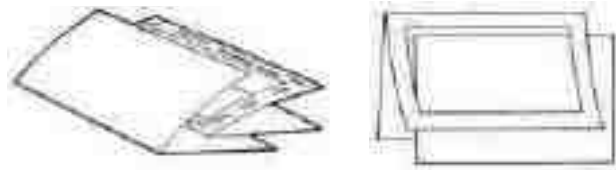
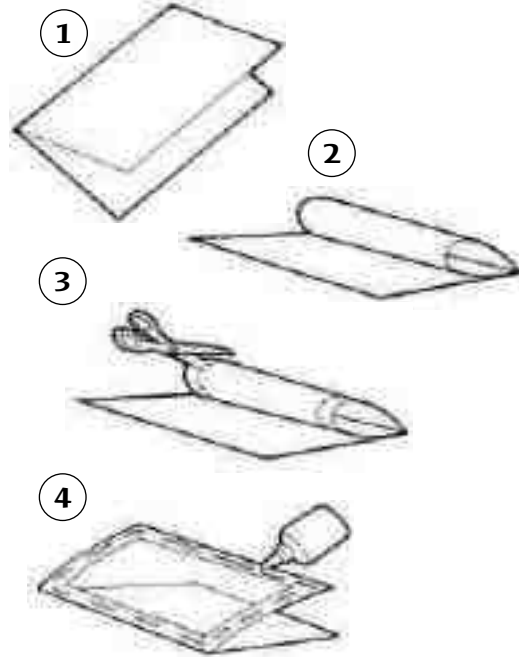

# Two-Tab Book

1. Take a *folded book* and cut up the *valley* of the inside fold toward the *mountain top*. This cut forms two large tabs that can be used front and back for writing and illustrations.
2. The book can be expanded by making several of these folds and gluing them side-by-side.

Use this book with data occurring in twos. For example, use it for comparing and contrasting, determining cause and effect, finding similarities and differences, and more.

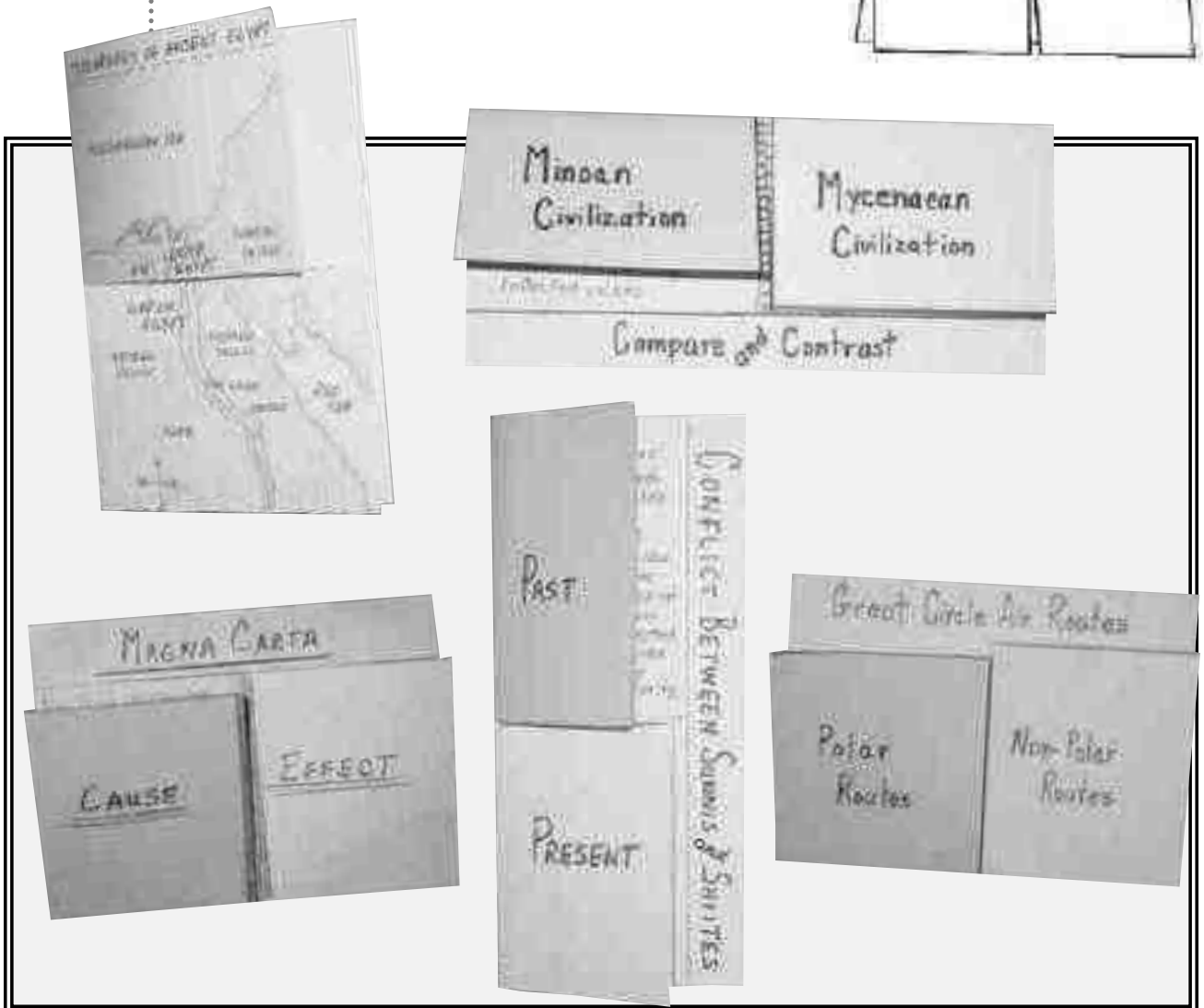
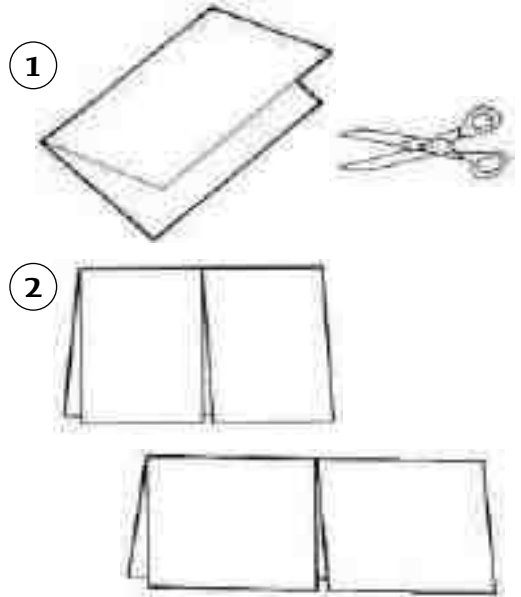

# Pocket Book

1. Fold a sheet of paper (8 1/2" x 11") in half like a *hamburger*.
2. Open the folded paper and fold one of the long sides up two inches to form a pocket. Refold along the *hamburger* fold so that the newly formed pockets are on the inside.
3. Glue the outer edges of the two-inch fold with a small amount of glue.
4. **Optional:** Glue a cover around the *pocket book*.

**Variation:** Make a multi-paged booklet by gluing several pockets side-by-side. Glue a cover around the multi-paged *pocket book*.

Use 3" x 5" index cards and quarter-sheets of notebook paper inside the pockets. Store student-made books, such as two-tab books and folded books in the pockets.

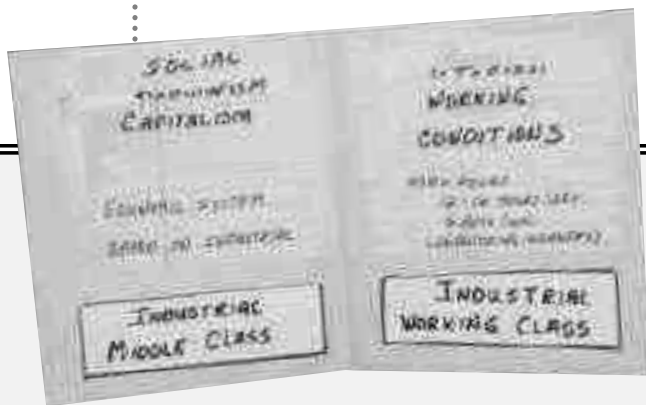
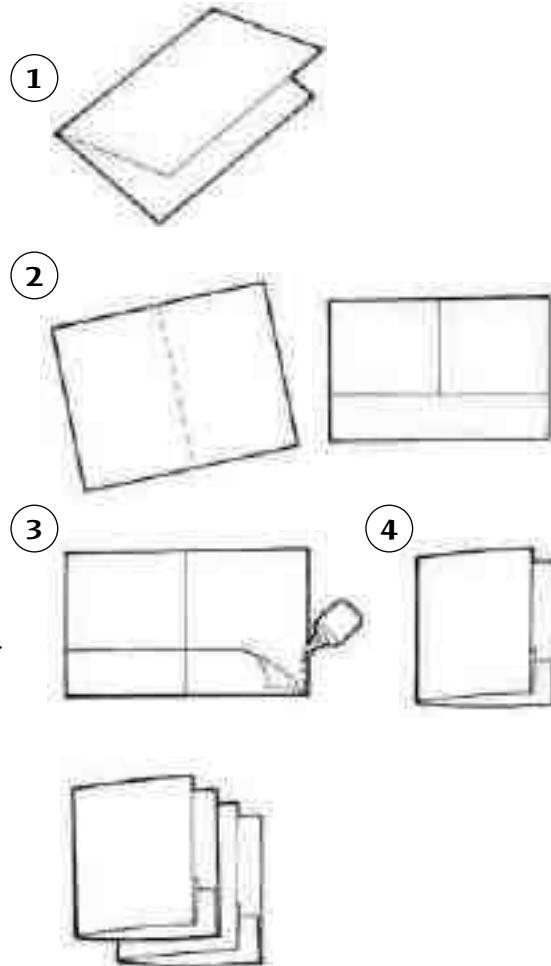



# Matchbook

1. Fold a sheet of paper (8 1/2" x 11") like a *hamburger*, but fold it so that one side is one inch longer than the other side.
2. Fold the one-inch tab over the short side forming an envelopelike fold.
3. Cut the front flap in half toward the *mountain top* to create two flaps.

Use this book to report on one thing, such as one person, place, or thing, or for reporting on two things.

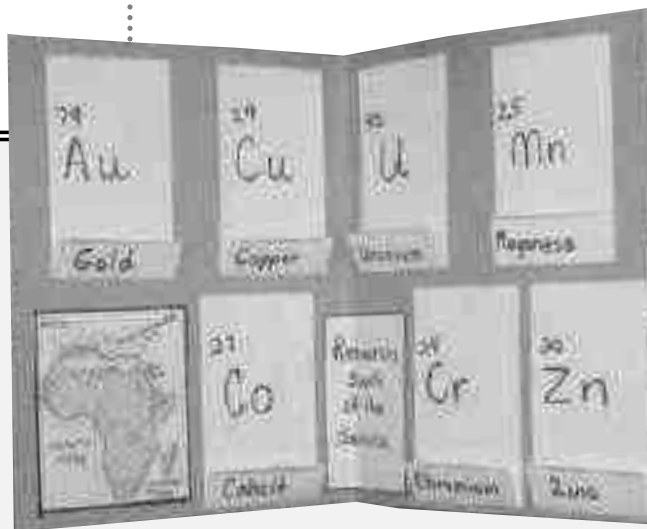
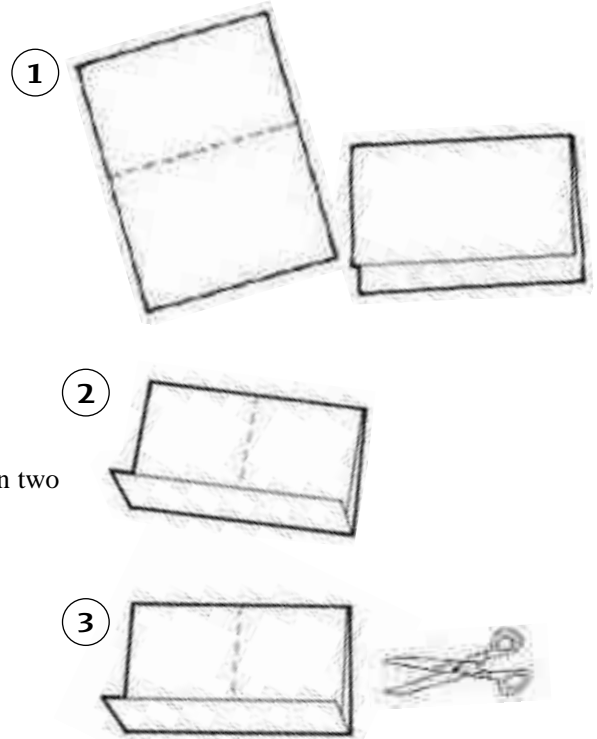

# Shutter Fold

1. Begin as if you were going to make a *hamburger* but instead of creasing the paper, pinch it to show the midpoint.
2. Fold the outer edges of the paper to meet at the pinch, or mid-point, forming a *shutter fold*.

Use this book for data occurring in twos. Or, make this fold using 11" x 17" paper and smaller books—such as the half book, journal, and two-tab book—that can be glued inside to create a large project full of student work.

①

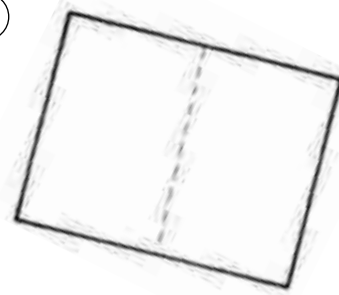

②

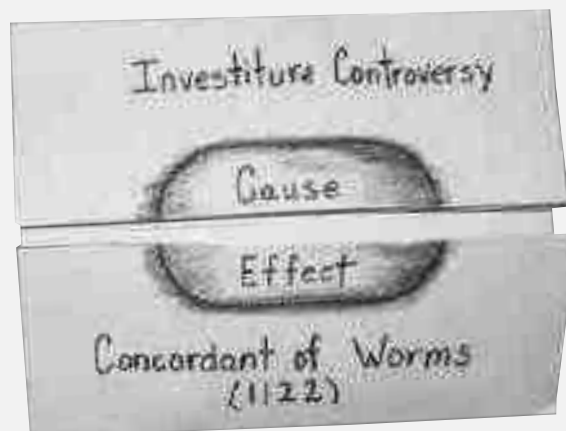
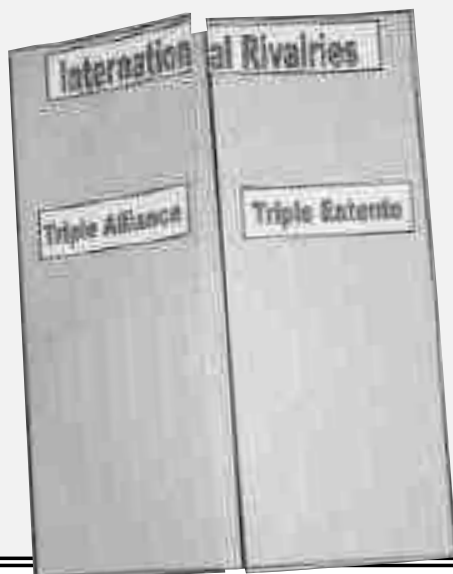

# Forward-Backward Book

1. Stack three or more sheets of paper. On the top sheet trace a large circle.
2. With the papers still stacked, cut out the circles.
3. Staple the paper circles together along the left-hand side to create a book.
4. Label the cover and takes notes on the pages that open to the right.
5. Turn the book upside down and label the back. Takes notes on the pages that open to the right.

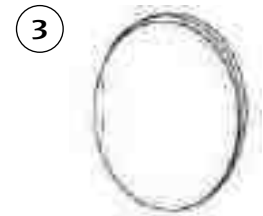
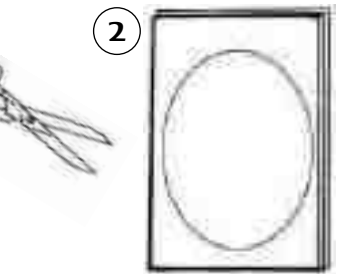
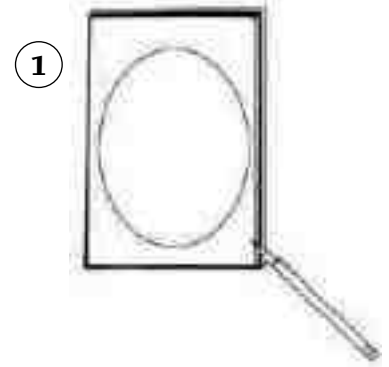

Front



Back



Front



Back



Use one Forward-Backward book to compare and contrast two people, places, things, or events.

# Three-Tab Book

1. Fold a sheet of paper like a *hot dog*.
2. With the paper horizontal, and the fold of the *hot dog* up, fold the right side toward the center, trying to cover one half of the paper.

**NOTE:** If you fold the right edge over first, the final graphic organizer will open and close like a book.

3. Fold the left side over the right side to make a book with three folds.
4. Open the folded book. Place your hands between the two thicknesses of paper and cut up the two *valleys* on one side only. This will form three tabs.

Use this book for data occurring in threes, and for two-part Venn diagrams.

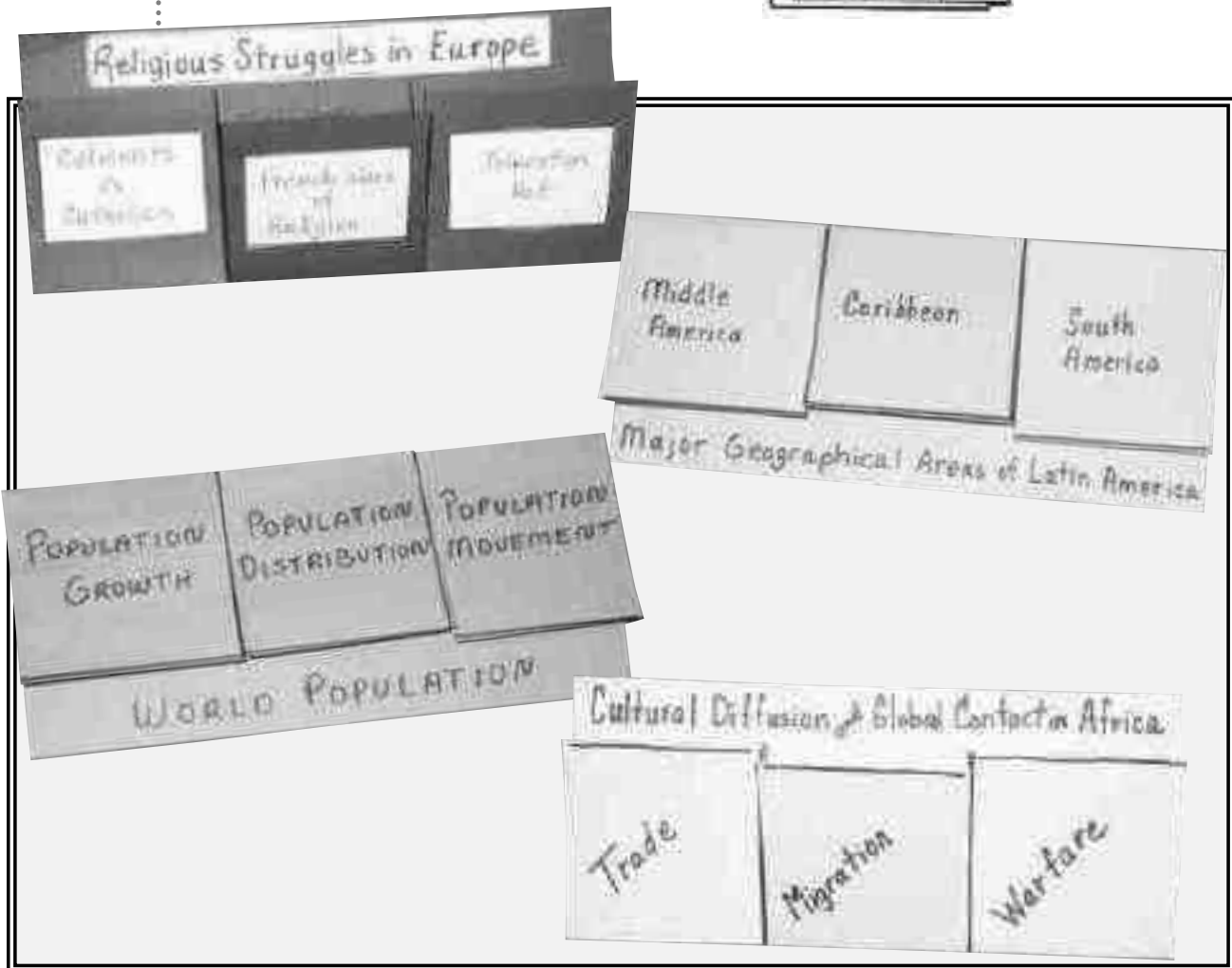
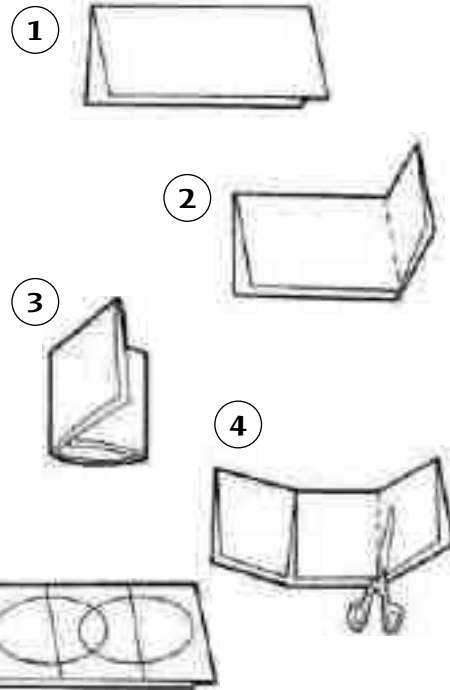

# Three-Tab Book Variations

**VARIATION A:**

Draw overlapping circles on the three tabs to make a Venn Diagram

**VARIATION B:**

Cut each of the three tabs in half to make a six-tab book.

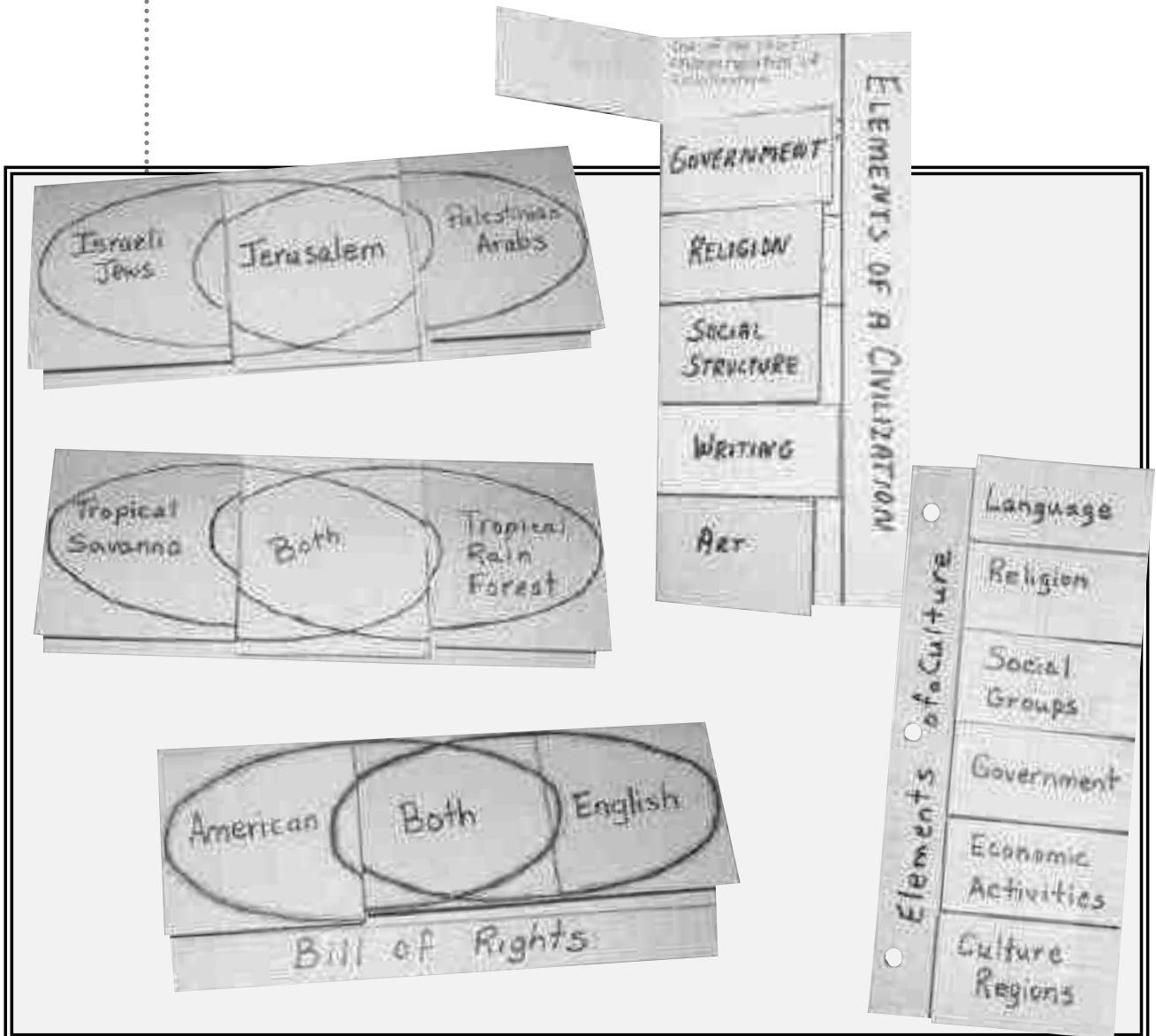
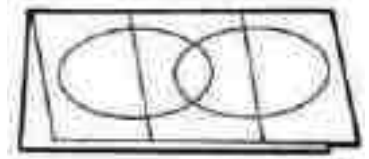

# Pyramid Fold

1. Fold a sheet of paper (8 1/2" x 11") into a *taco*, forming a square. Cut off the excess rectangular tab formed by the fold.
2. Open the folded *taco* and refold it the opposite way forming another *taco* and an X-fold pattern.
3. Cut one of the folds to the center of the X, or the midpoint, and stop. This forms two triangular-shaped flaps.
4. Glue one of the flaps under the other, forming a *pyramid*.
5. Label front sections and write information, notes, thoughts, and questions inside the pyramid on the back of the appropriate tab.

Use to make mobiles and dioramas.  
Use with data occurring in threes.

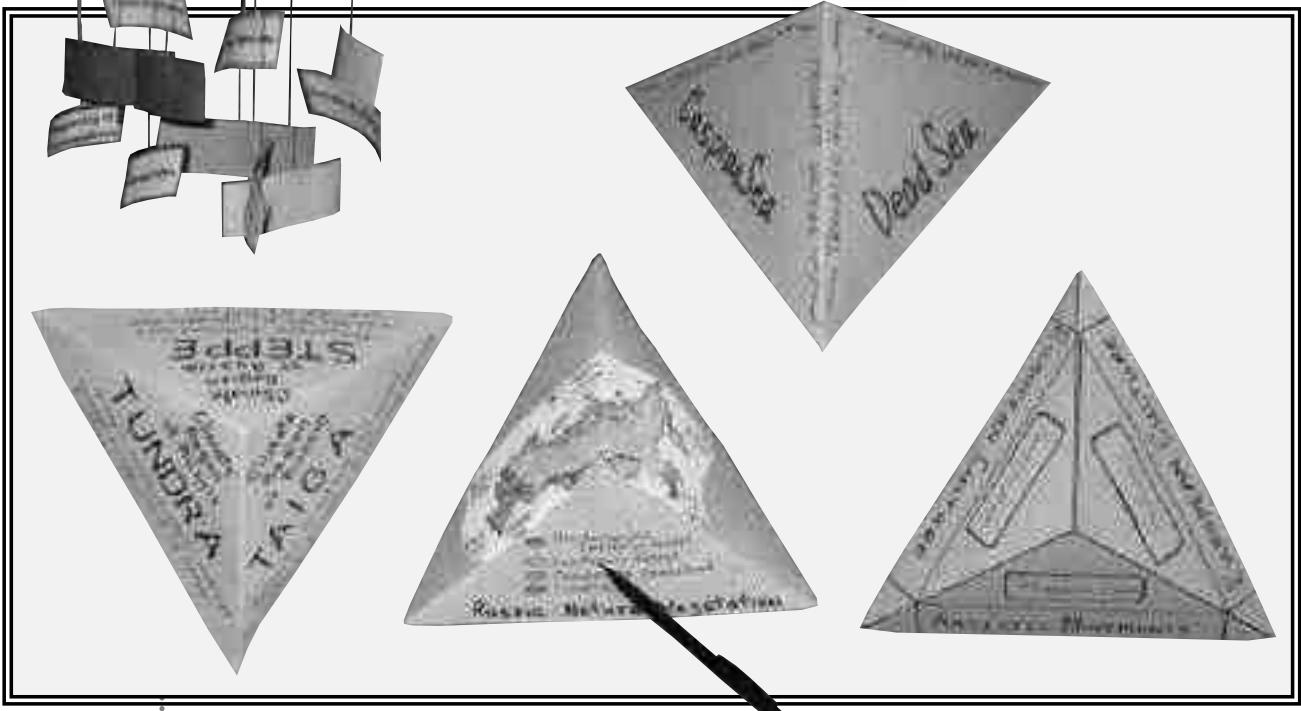
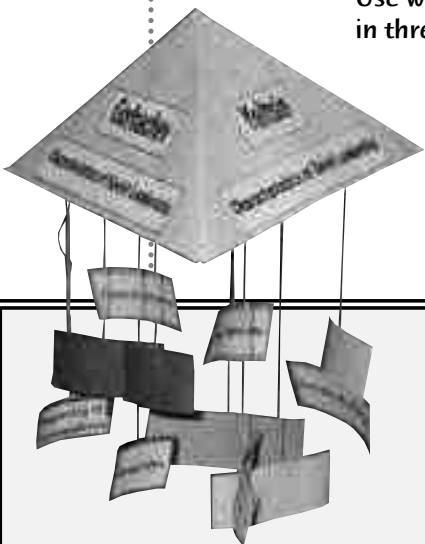
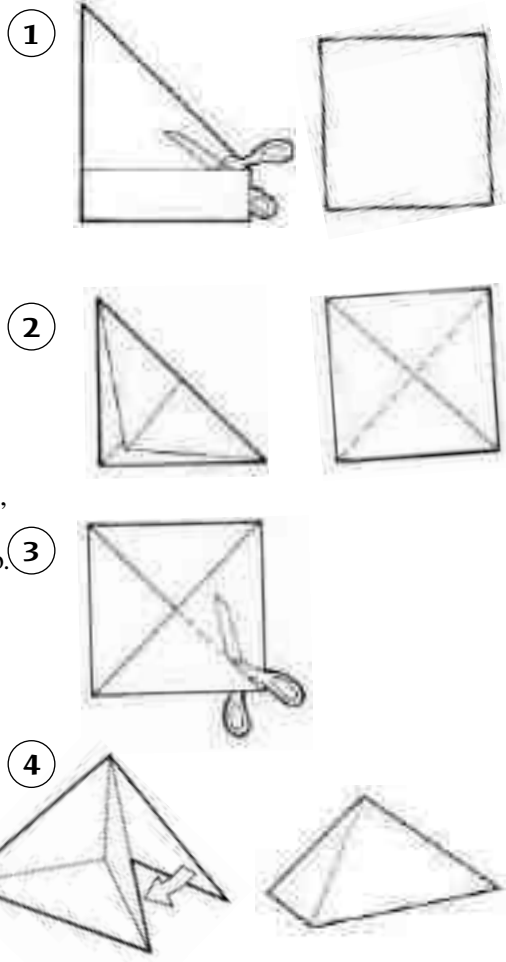

# Trifold Book

1. Fold a sheet of paper (8 1/2" x 11") into thirds.
2. Use this book as is, or cut into shapes. If the trifold is cut, leave plenty of fold on both sides of the designed shape, so the book will open and close in three sections.

Use this book to make charts with three columns or rows, large Venn diagrams, and reports on data occurring in threes.

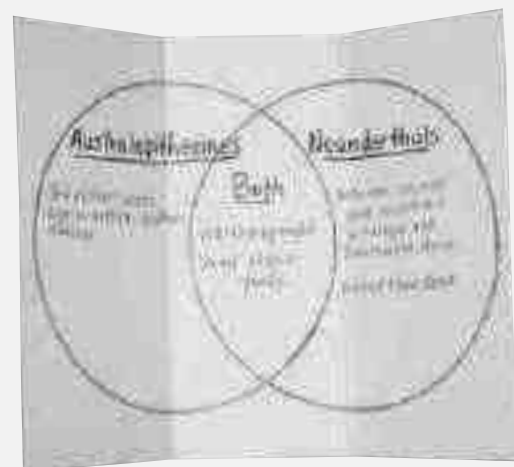
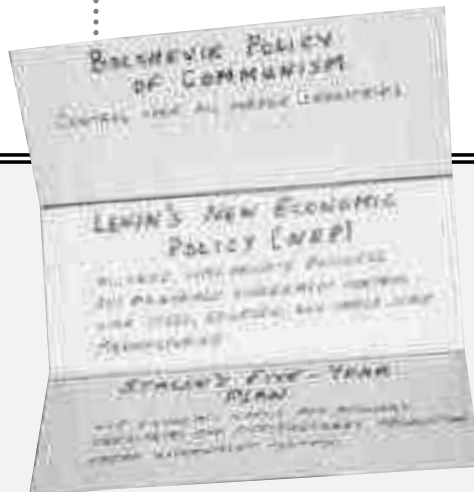
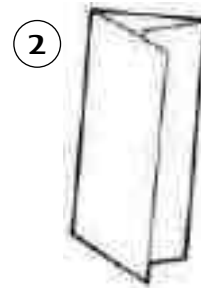
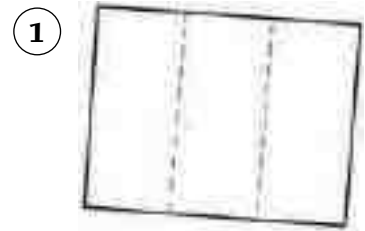

# Three-Pocket Book

1. Fold a horizontal sheet of paper (11" x 17") into thirds.
2. Fold the bottom edge up two inches and crease well. Glue the outer edges of the two inch tab to create three pockets.
3. Label each pocket. Use to hold notes taken on index cards or quarter sheets of paper.

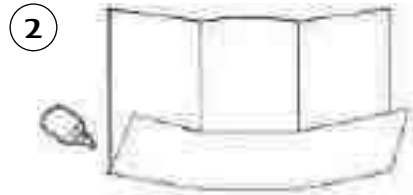
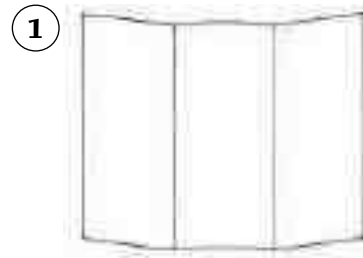



# Four-Tab Book

1. Fold a sheet of paper (8 1/2" x 11") in half like a *hot dog*.
2. Fold this long rectangle in half like a *hamburger*.
3. Fold both ends back to touch the *mountain top* or *fold it like an accordion*.
4. On the side with two *valleys* and one *mountain top*, make vertical cuts through one thickness of paper, forming four tabs.

Use this book for data occurring in fours.

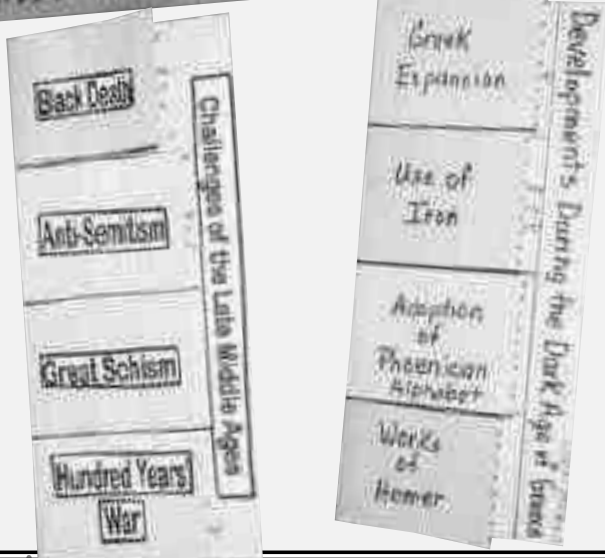
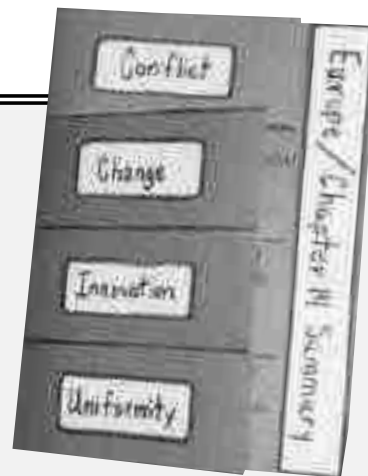
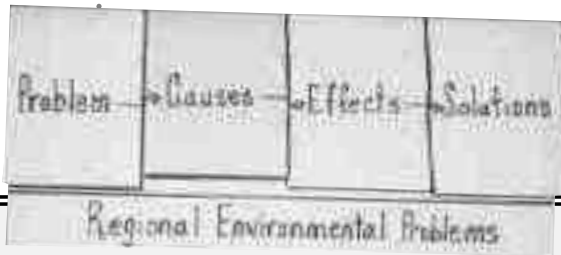
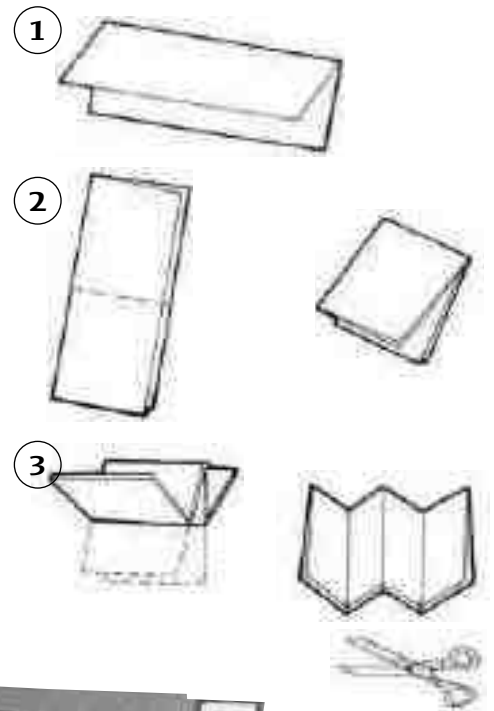

# Standing Cube

1. Use two sheets of the same size paper. Fold each like a *hamburger*. However, fold one side one half inch shorter than the other side. This will make a tab that extends out one half inch on one side.
2. Fold the long side over the short side of both sheets of paper, making tabs.
3. On one of the folded papers, place a small amount of glue along the the small folded tab, next to the *valley* but not in it.
4. Place the non-folded edge of the second sheet of paper square into the *valley* and fold the glue-covered tab over this sheet of paper. Press flat until the glue holds. Repeat with the other side.
5. Allow the glue to dry completely before continuing. After the glue has dried, the cube can be collapsed flat to allow students to work at their desks. The cube can also be folded into fourths for easier storage, or for moving it to a display area.

Use with data occurring in fours or make it into a project. Make a small display cube using 8 1/2" x 11" paper. Use 11" x 17" paper to make large project cubes that you can glue other books onto for display. Notebook paper, photocopied sheets, magazine pictures, and current events also can be displayed on the large cube.

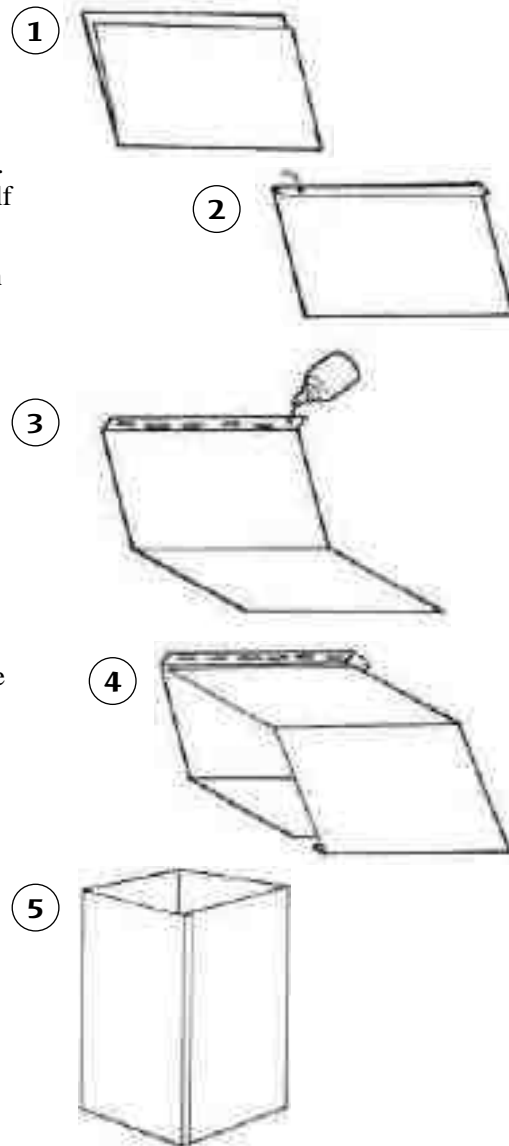

This large cube project can be stored in plastic bag portfolios.

# Four-Door Book

1. Make a *shutter fold* using 11" x 17" or 12" x 18" paper.
2. Fold the *shutter fold* in half like a *hamburger*. Crease well.
3. Open the project and cut along the two inside *valley folds*.
4. These cuts will form four doors on the inside of the project.

Use this fold for data occurring in fours. When folded in half like a *hamburger*, a finished *four-door book* can be glued inside a large (11" x 17") *shutter fold* as part of a larger project.

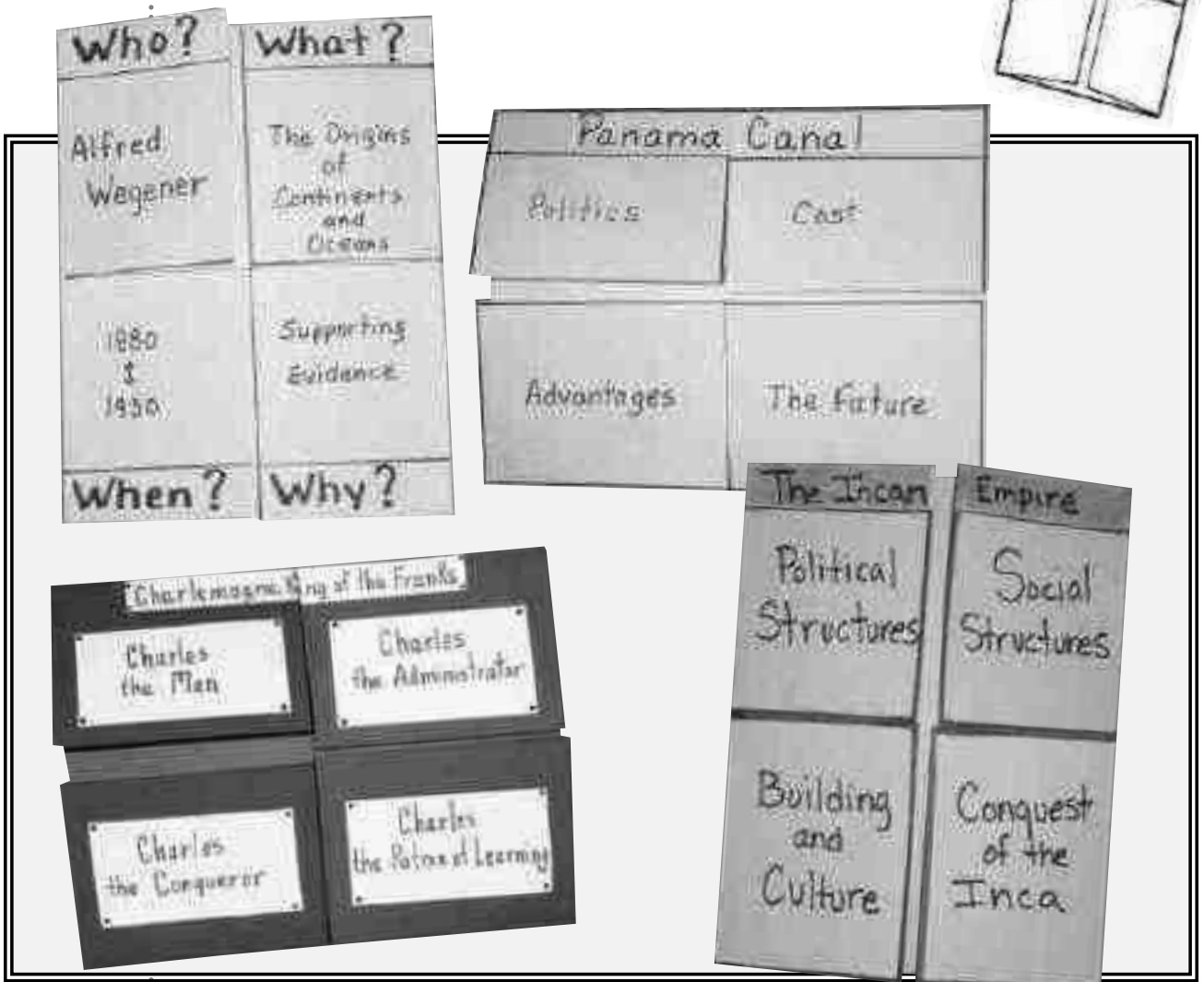
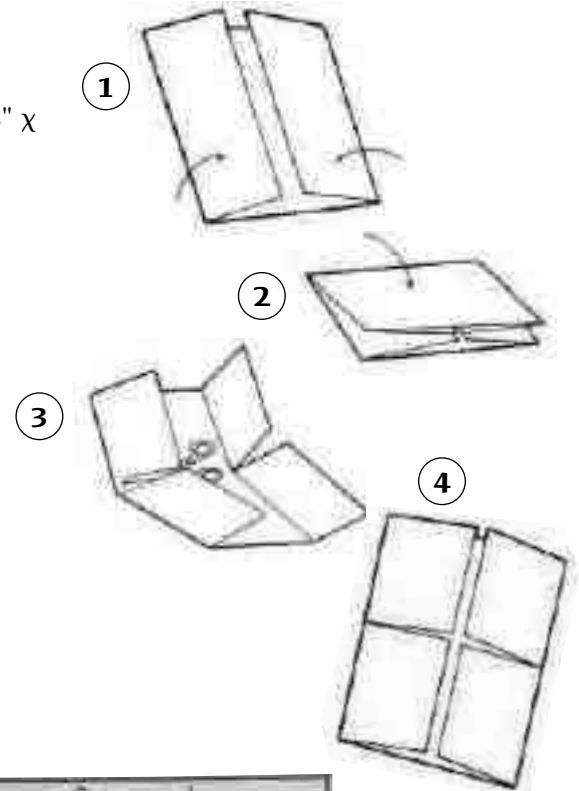

# Envelope Fold

1. Fold a sheet of paper (8 1/2" x 11") into a taco forming a square. *Cut off the excess paper strip formed by the square.*
2. *Open the folded taco and refold it the opposite way forming another taco and an X fold pattern.*
3. *Open the taco fold and fold the corners toward the center point of the X forming a small square.*
4. Trace this square on another sheet of paper. Cut and glue it to the inside of the envelope. Pictures can be placed under or on top of the tabs, or can be used to teach fractional parts.

Use this book for data occurring in fours.

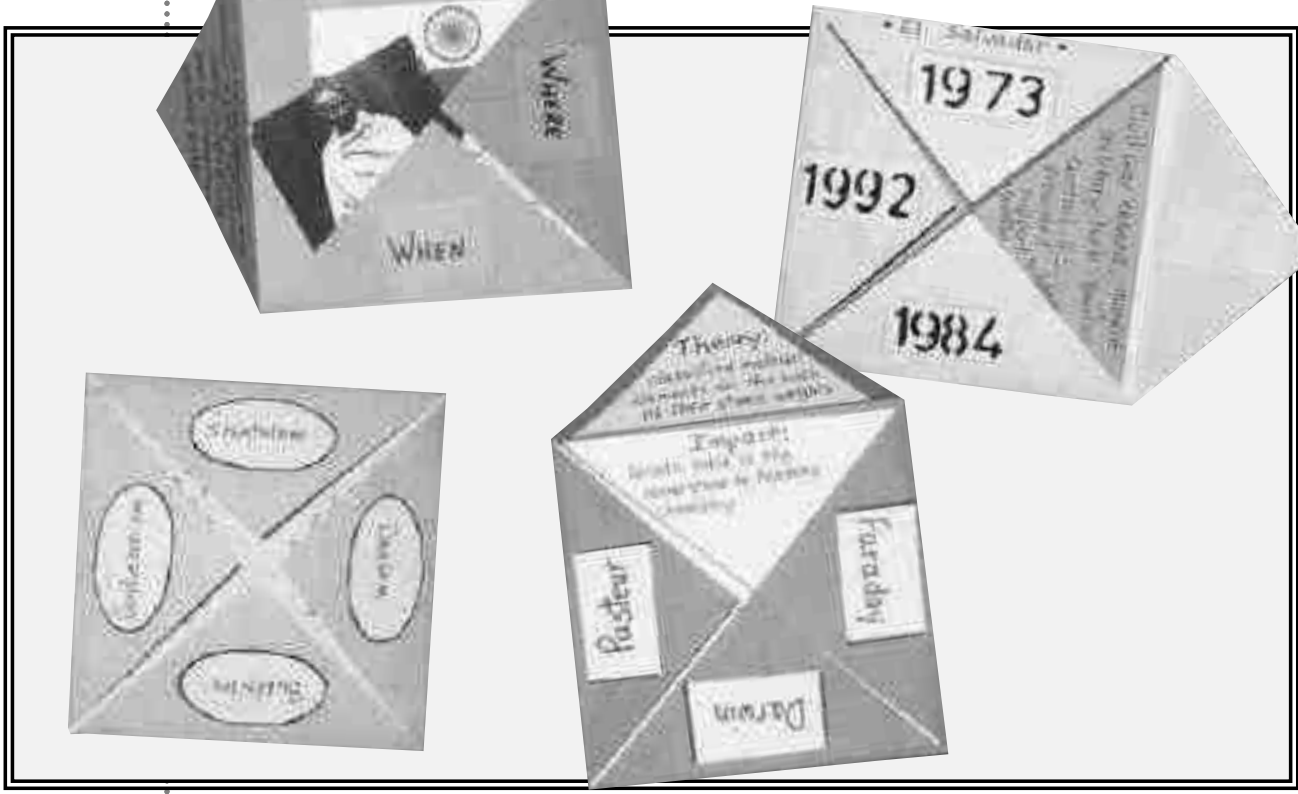
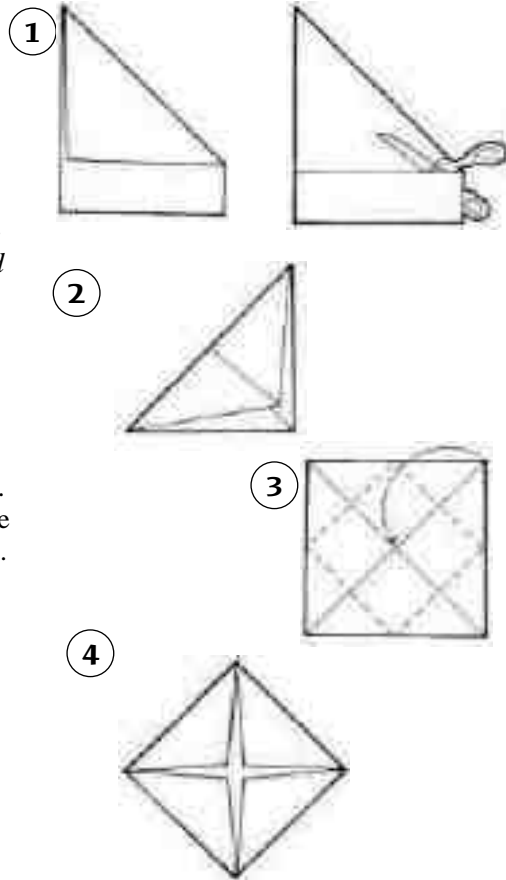

# Layered-Look Book

1. Stack two sheets of paper (8 1/2" x 11") so that the back sheet is one inch higher than the front sheet.
2. Bring the bottom of both sheets upward and align the edges so that all of the layers or tabs are the same distance apart.
3. When all tabs are an equal distance apart, fold the papers and crease well.
4. Open the papers and glue them together along the *valley* or inner center fold or, staple them along the *mountain*.

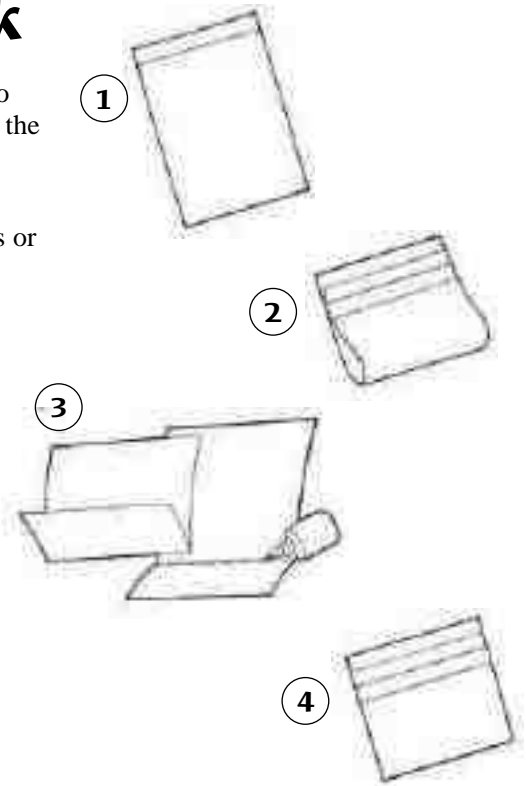

When using more than two sheets of paper, make the tabs smaller than an inch.

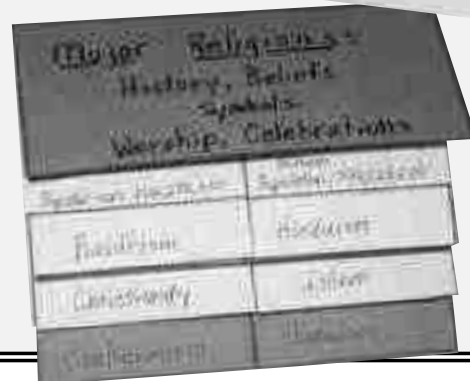
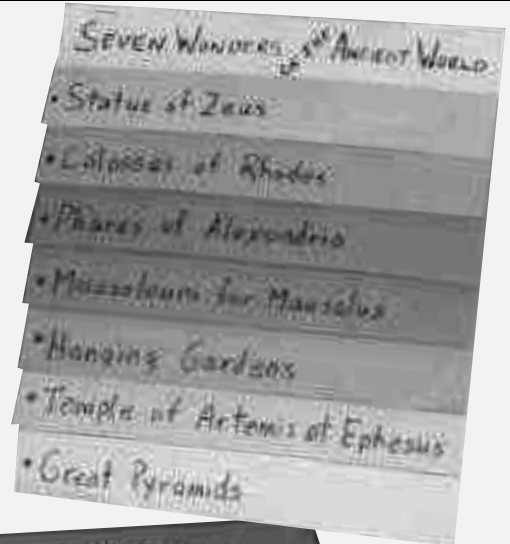

# Top-Tab Book

1. Fold a sheet of paper (8 1/2" x 11") in half like a *hamburger*. Cut the center fold, forming two half sheets.
2. Fold one of the half sheets four times. Begin by folding in half like a *hamburger*, fold again like a *hamburger*, and finally again like a *hamburger*. This folding has formed your pattern of four rows and four columns, or 16 small squares.
3. Fold two sheets of paper (8 1/2" x 11") in half like a *hamburger*. Cut the center folds, forming four half sheets.
4. Hold the pattern vertically and place on a half sheet of paper under the pattern. Cut the bottom right hand square out of both sheets. Set this first page aside.
5. Take a second half sheet of paper and place it under the pattern. Cut the first and second right hand squares out of both sheets. Place the second page on top of the first page.

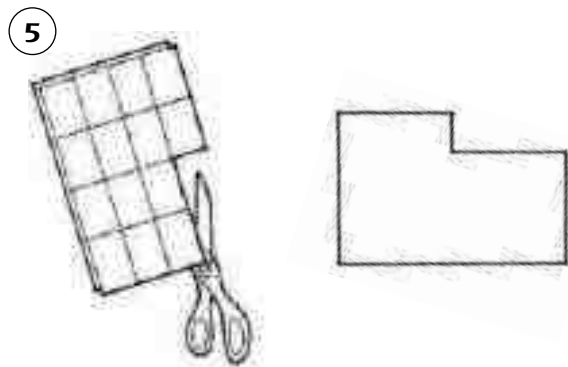
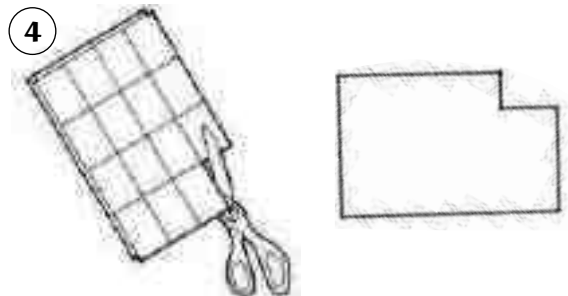
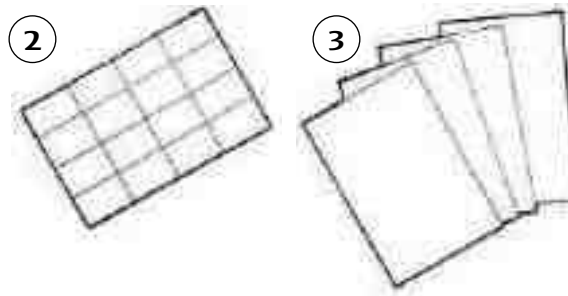
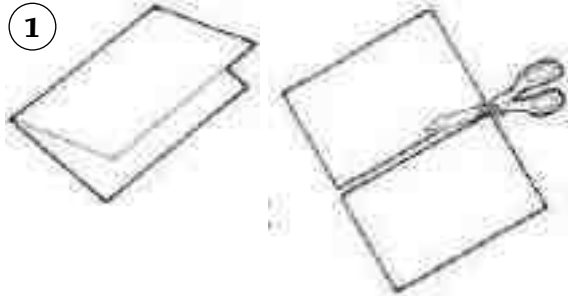

6. Take a third half sheet of paper and place it under the pattern. Cut the first, second, and third right hand squares out of both sheets. Place this third page on top of the second page.
7. Place the fourth, uncut half sheet of paper behind the three cut out sheets, leaving four aligned tabs across the top of the book. Staple several times on the left side. You can also place glue along the left paper edges, and stack them together. The glued spine is very strong.
8. Cut a final half sheet of paper with no tabs and staple along the left side to form a cover.

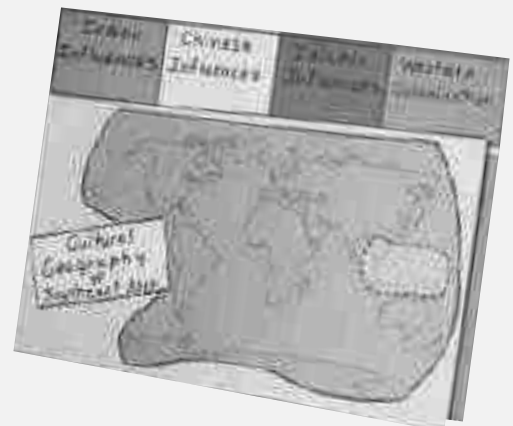
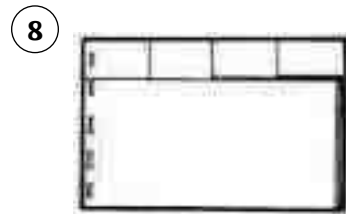
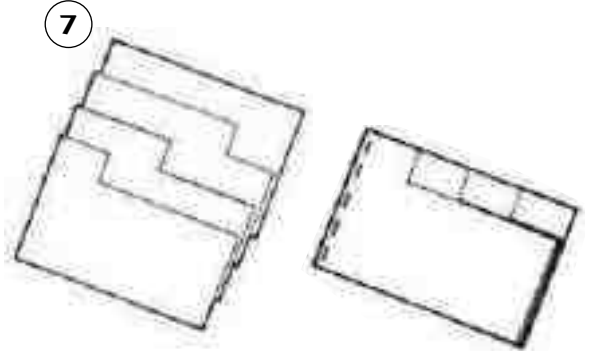
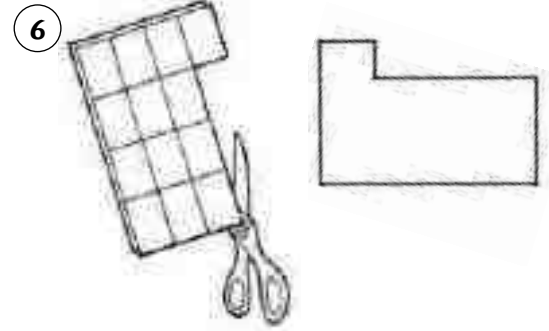

# Folding a Circle into Tenths

1. Fold a paper circle in half.
2. Fold the half circle so that one third is exposed and two thirds are covered.
3. Fold the one third (single thickness) backward to form a fold line.
4. Fold the two thirds section in half.
5. The half circle will be divided into fifths. When opened, the circle will be divided into tenths.

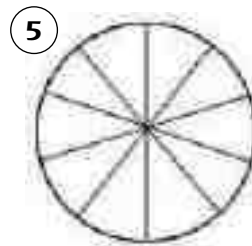
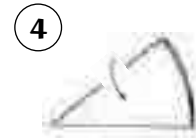
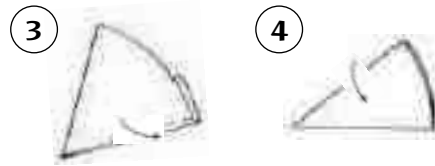
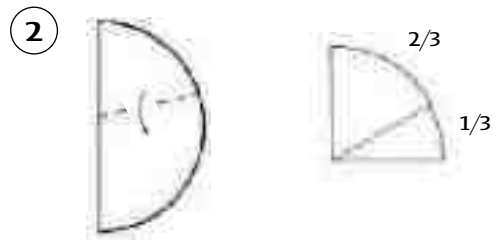
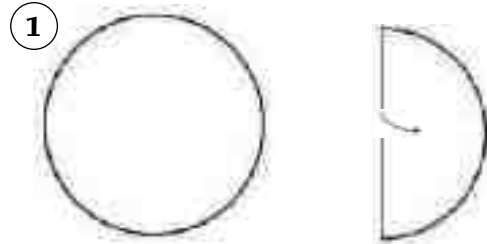

**NOTE:** Paper squares and rectangles are folded into tenths the same way. Fold them so that one third is exposed and two thirds is covered. Continue with steps 3 and 4.

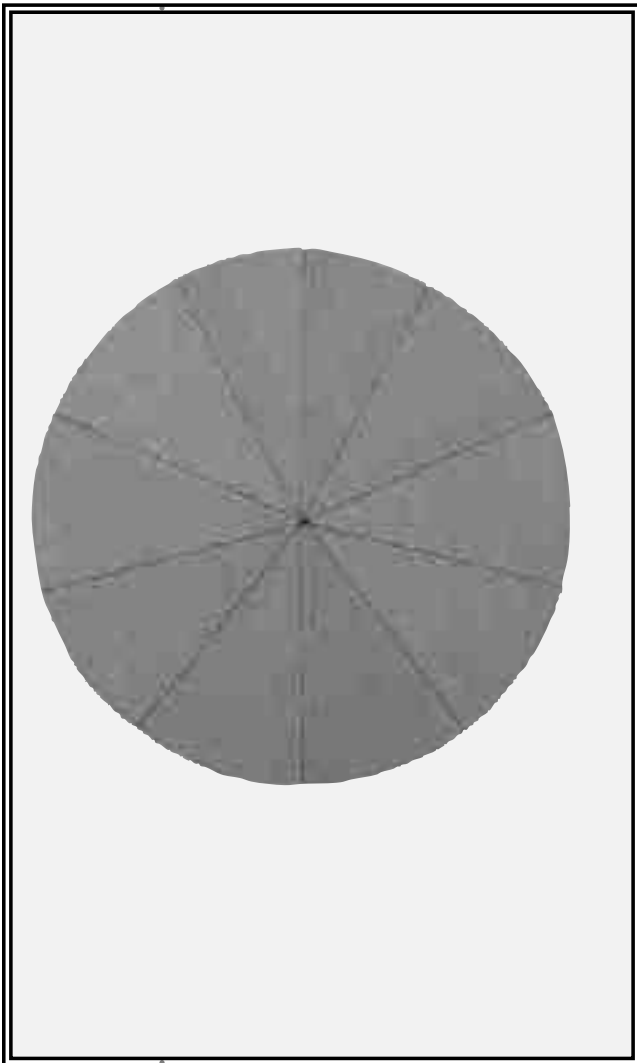



# Circle Graph

1. Cut out two circles using a pattern.
2. Fold one of the circles in half on each axis, forming fourths. Cut along one of the fold lines (the radius) to the middle of each circle. Flatten the circle.
3. Slip the two circles together along the cuts until they overlap completely.
4. Spin one of the circles while holding the other stationary. Estimate how much of each of the two (or you can add more) circles should be exposed to illustrate given percentages or fractional parts of data. Add circles to represent more than two percentages.

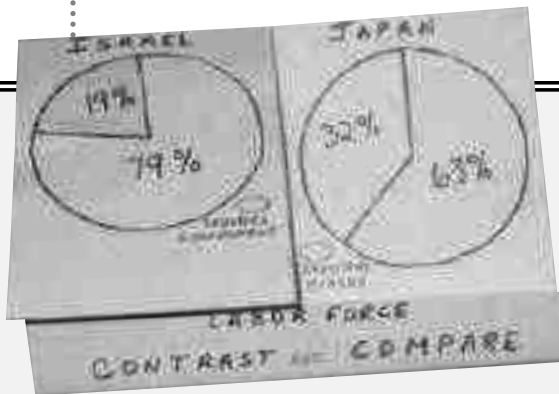
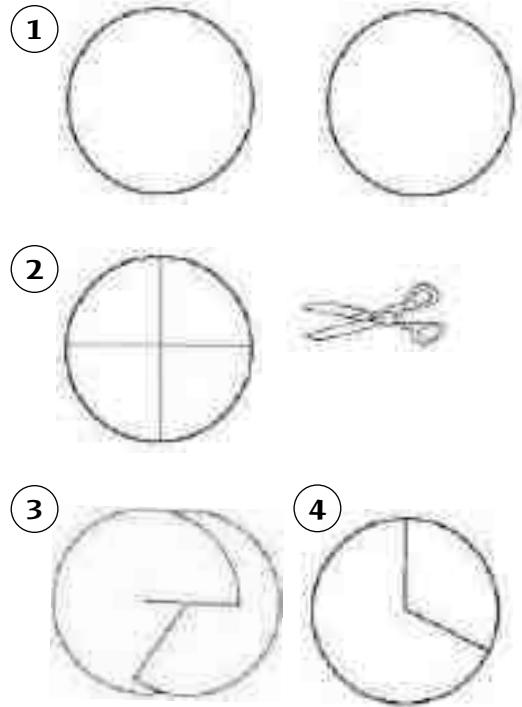

Use large circle graphs on bulletin boards.

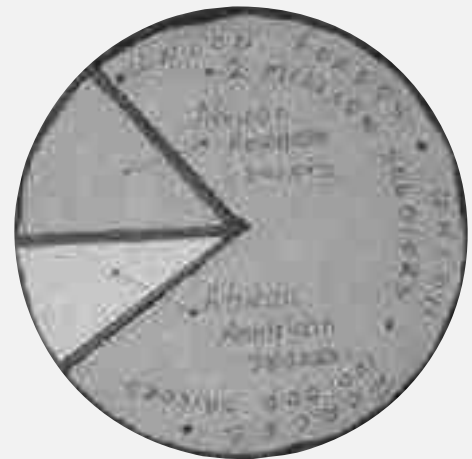

Use small circle graphs in student projects or on the front of tab books.

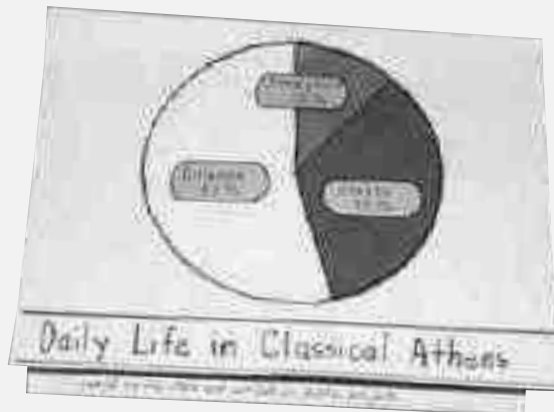

# Folding into Fifths

1. Fold a sheet of paper in half like a *hotdog* or *hamburger* for a five tab book, or leave open for a folded table or chart.
2. Fold the paper so that one third is exposed and two thirds are covered.
3. Fold the two thirds section in half.
4. Fold the one third section (single thickness) backward to form a fold line.

The paper will be divided into fifths when opened.

1



2

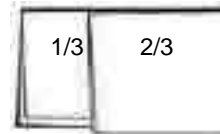

3



4

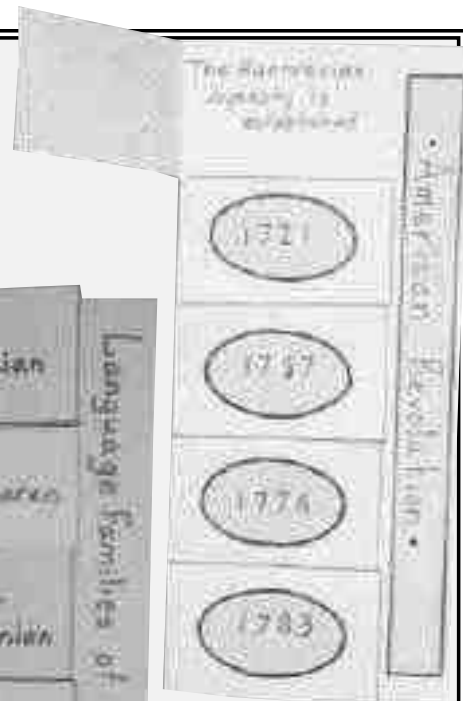

# Folded Table or Chart

1. Fold the number of vertical columns needed to make the table or chart.
2. Fold the horizontal rows needed to make the table or chart.
3. Label the rows and columns.

*Remember:* Tables are organized along vertical and horizontal axes, while charts are organized along one axis, either horizontal or vertical.

**Table**

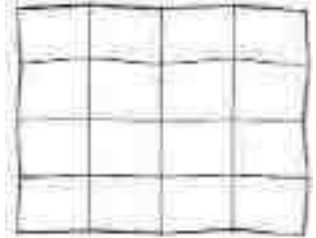

**Chart**

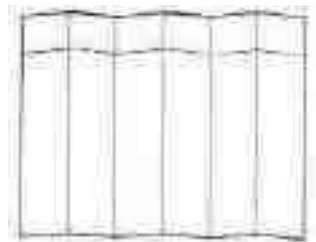

CHAPTER 5 - THE LAND

PHYSICAL FEATURES	LOCATION
CASCADE RANGE	in the Pacific Northwest
GREAT PLAINS	in the central United States
CANADIAN SHIELD	in the north of North America
APPALACHIAN MOUNTAINS	in the eastern United States

Timeline	Mayan	Toltec	Aztec
500 AD - 900 AD	Classic Maya	Teotihuacan	Maya
900 AD - 1500 AD	Postclassic Maya	Cholula	Maya
1500 AD - 1600 AD	Colonial	Spanish	Spanish
1600 AD - 1800 AD	18th Century	18th Century	18th Century
1800 AD - 1900 AD	19th Century	19th Century	19th Century
1900 AD - 2000 AD	20th Century	20th Century	20th Century

INDEX	MAYAN	TEOTIACACAN
DATES	500 BC - 900 AD	1000 BC - 300 AD
GOVERNMENT	City States	City States
ECONOMY	Barter	Barter

# Accordion Book

**NOTE:** Steps 1 and 2 should be done only if paper is too large to begin with.

1. Fold the selected paper into *hamburgers*.
2. Cut the paper in half along the fold lines.
3. Fold each section of paper into *hamburgers*. However, fold one side one half inch shorter than the other side. This will form a tab that is one half inch long.
4. Fold this tab forward over the shorter side, and then fold it back away from the shorter piece of paper (in other words, fold it the opposite way).
5. Glue together to form an *accordion* by gluing a straight edge of one section into the *valley* of another section.

**NOTE:** Stand the sections on end to form an accordion to help students visualize how to glue them together. (See illustration.)

Always place the extra tab at the back of the book so you can add more pages later.

Use this book for time lines, student projects that grow, sequencing events or data, and biographies.

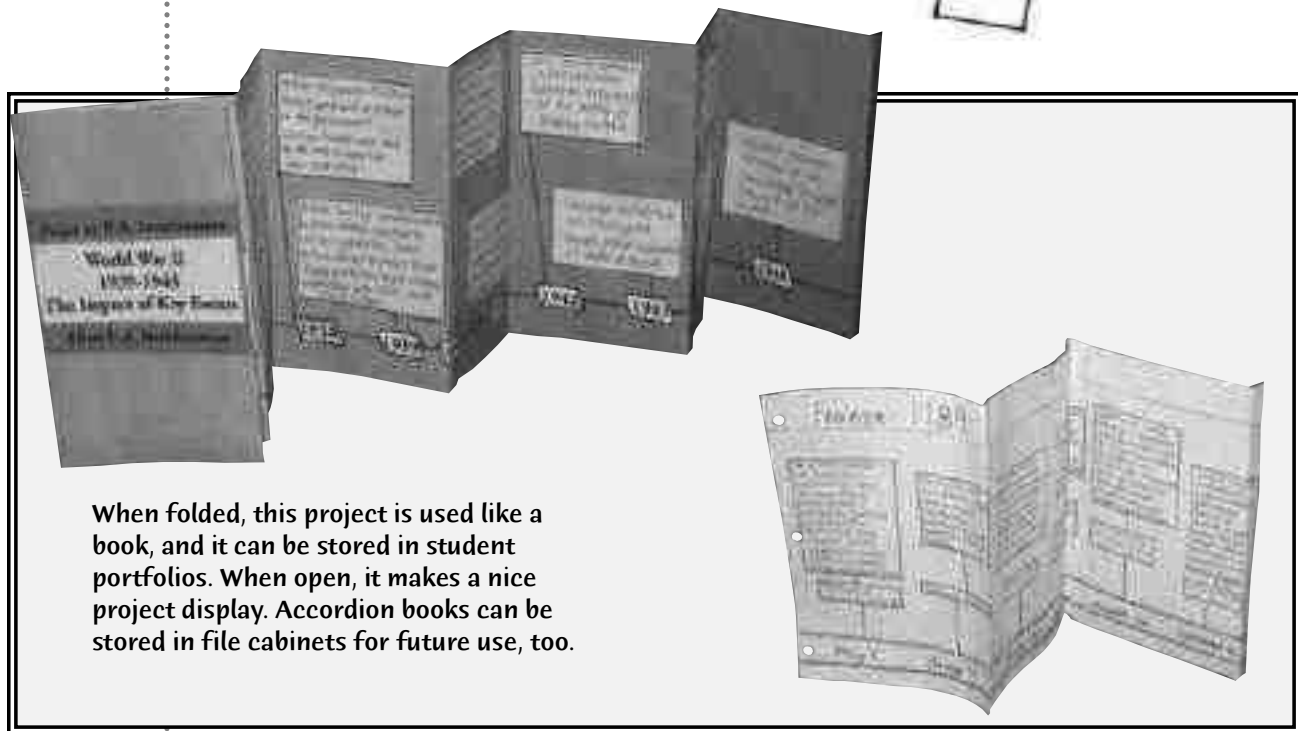
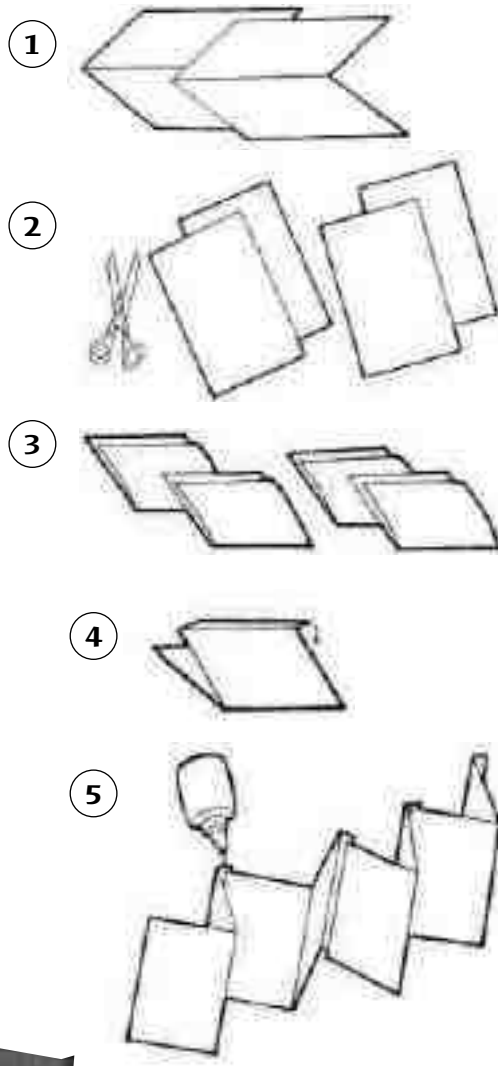

When folded, this project is used like a book, and it can be stored in student portfolios. When open, it makes a nice project display. Accordion books can be stored in file cabinets for future use, too.

# Pop-Up Book

1. Fold a sheet of paper (8 1/2" x 11") in half like a *hamburger*.
2. Beginning at the fold, or *mountain* top, cut one or more tabs.
3. Fold the tabs back and forth several times until there is a good fold line formed.
4. Partially open the *hamburger* fold and push the tabs through to the inside.
5. With one small dot of glue, glue figures for the *pop-up book* to the front of each tab. Allow the glue to dry before going on to the next step.
6. Make a cover for the book by folding another sheet of paper in half like a *hamburger*. Place glue around the outside edges of the *pop-up book* and firmly press inside the *hamburger* cover.

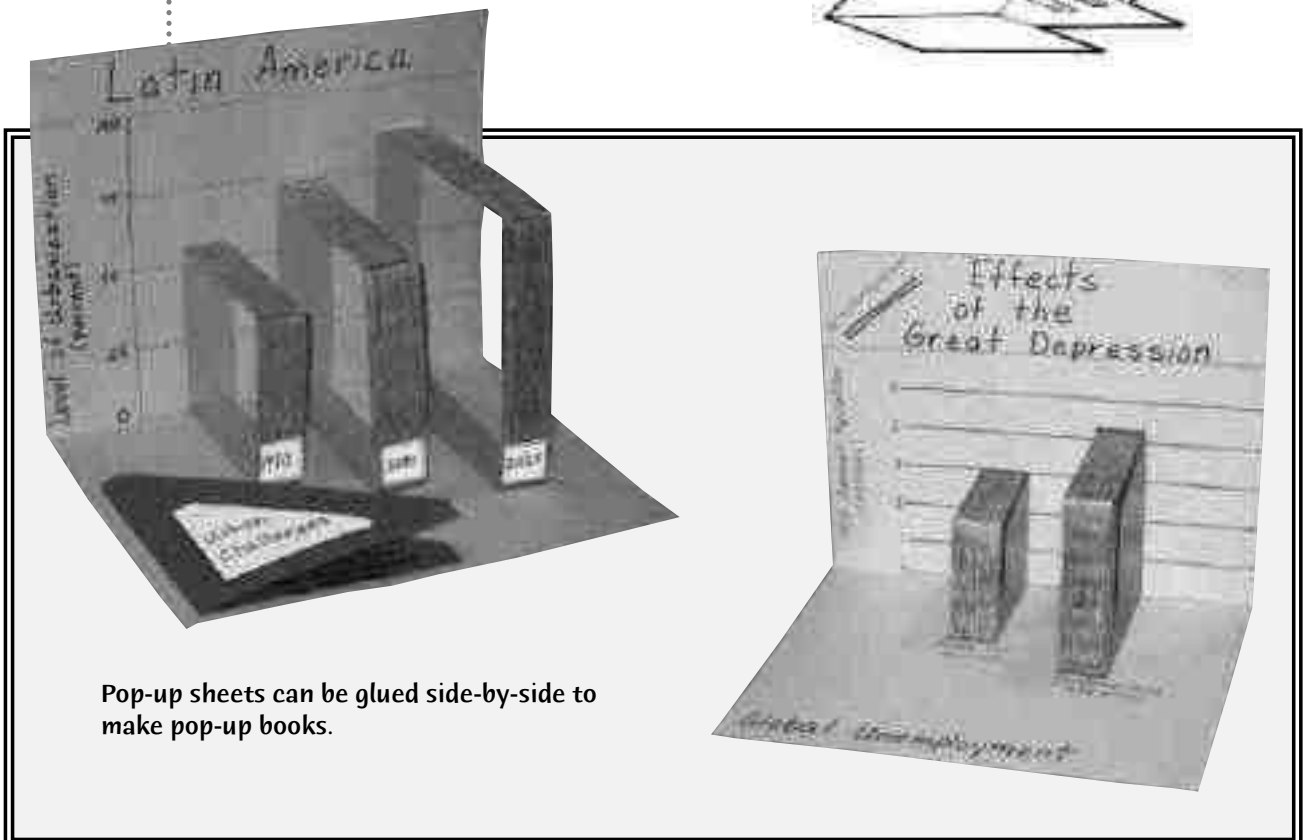
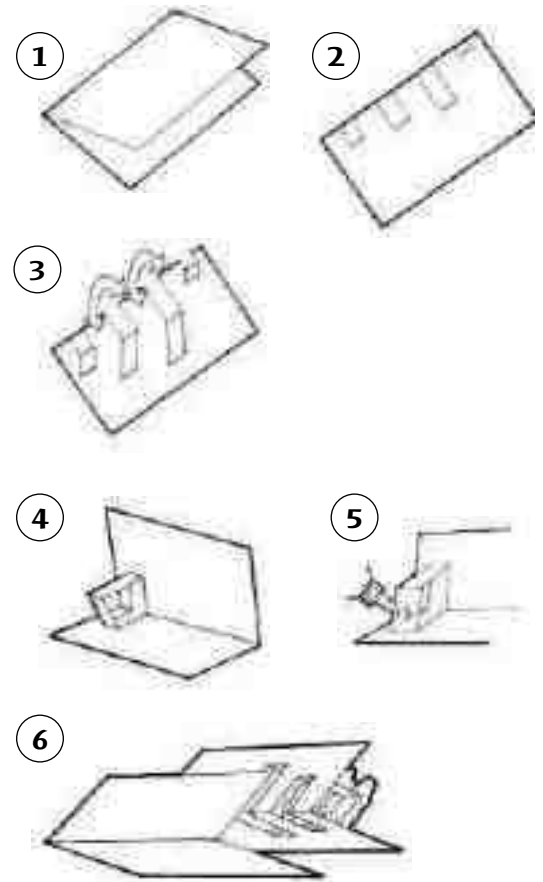

Pop-up sheets can be glued side-by-side to make pop-up books.

# Four-Door Diorama

1. Make a *four-door book* out of a *shutter fold*.
2. Fold the two inside corners back to the outer edges (*mountains*) of the *shutter fold*. This will result in two *tacos* that will make the *four-door book* look like it has a shirt collar. Do the same thing to the bottom of the *four-door book*. When finished, four small triangular *tacos* have been made.
3. Form a 90-degree angle and overlap the folded triangles to make a display case that doesn't use staples or glue. (It can be collapsed for storage.)
4. Or, as illustrated, cut off all four triangles, or *tacos*. Staple or glue the sides.

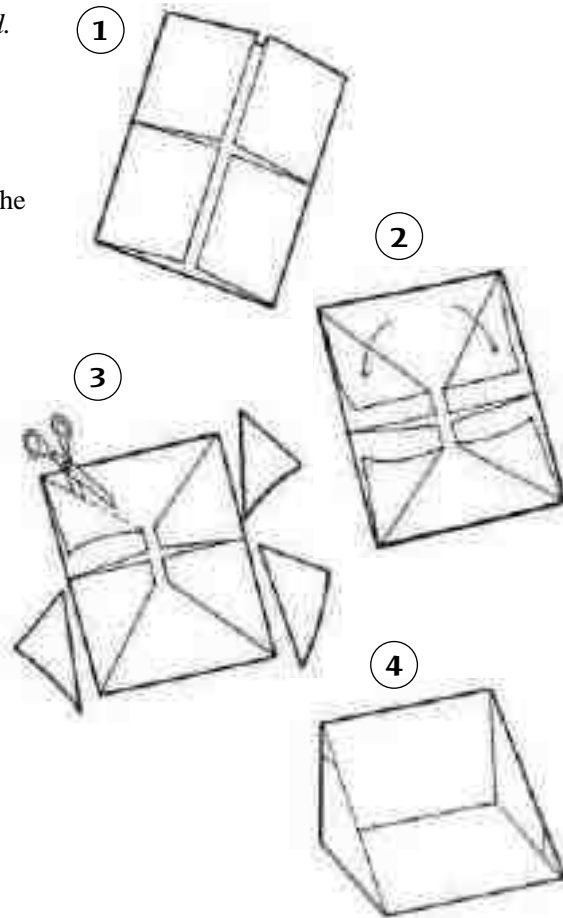

Glue display cases end-to-end to compare and contrast or to sequence events or data.

Use 11" x 17" paper to make a large display case.

Use poster board to make giant display cases.



# Concept-Map Book

1. Fold a sheet of paper along the long or short axis, leaving a two-inch tab uncovered along the top.
2. Fold in half or in thirds.
3. Unfold and cut along the two or three inside fold lines.

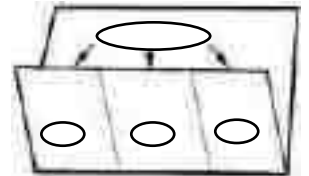
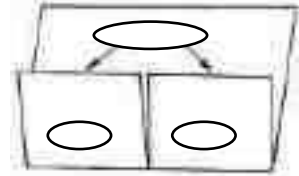

**Vernacular Literature**

- Troubadour Poetry
- Chanson de geste

**BERLIN WALL**

- BEFORE
- DURING
- AFTER

**Monothelism**

- Judaism
- Christianity
- Islam

**Latin America's People**

- Who they are
- Where they live

**Map Projections**

- Planar
- Cylindrical
- Conic

**SPACE OBJECTS**

- ASTEROIDS
- COMETS
- METEOROIDS

## Project Board with Tabs

1. Draw a large illustration or a series of small illustrations or write on the front of one of the pieces of selected-size paper.
2. Pinch and slightly fold the paper at the point where a tab is desired on the illustrated project board. Cut into the paper on the fold. Cut straight in, then cut up to form an "L." When the paper is unfolded, it will form a tab with an illustration on the front.
3. After all tabs have been cut, glue this front sheet onto a second piece of paper. Place glue around all four edges and in the middle, away from tabs.

1

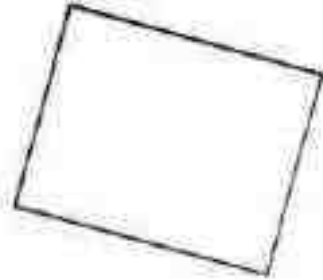

2

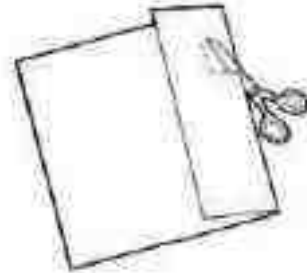

3

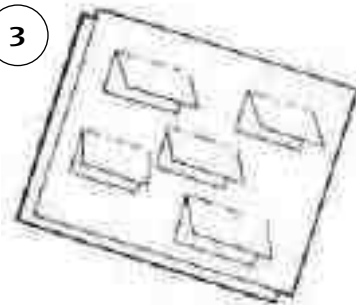

Write or draw under the tabs. If the project is made as a bulletin board using butcher paper, quarter and half-sheets of paper can be glued under the tabs.



# Billboard Project

1. Fold all pieces of the same size of paper in half like *hamburgers*.
2. Place a line of glue at the top and bottom of one side of each folded billboard section and glue them edge-to-edge on a background paper or project board. If glued correctly, all doors will open from right to left.
3. Pictures, dates, words, etc., go on the front of each billboard section. When opened, writing or drawings can be seen on the inside left of each section. The base, or the part glued to the background, is perfect for more in-depth information or definitions.

Use for time lines or sequencing data.

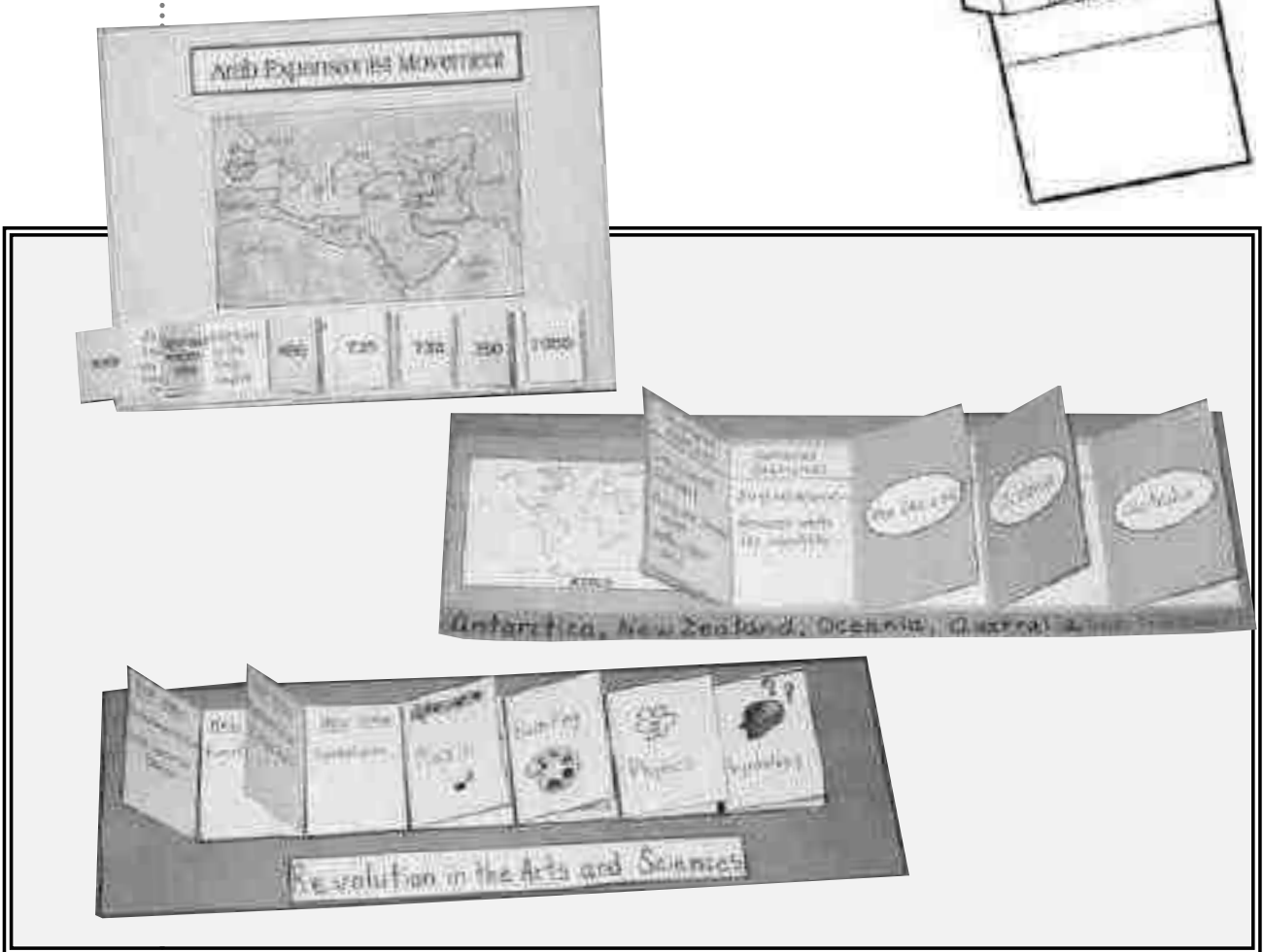
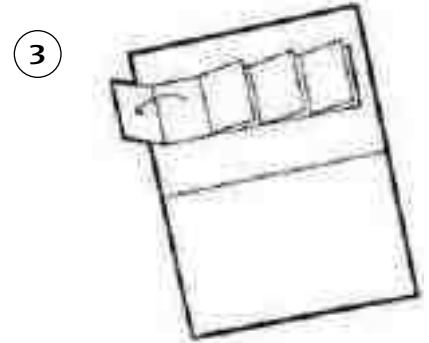
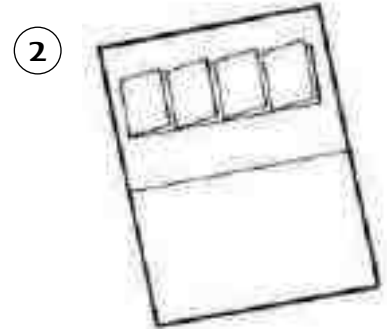

# Vocabulary Book

1. Fold a sheet of notebook paper in half like a *hotdog*.
2. On one side, cut every third line. This results in ten tabs on wide ruled notebook paper and twelve tabs on college ruled.
3. Label the tabs.

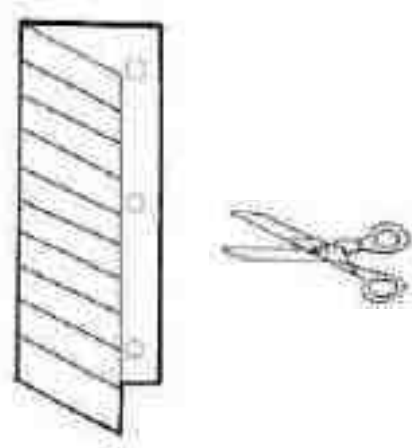

Use for recording student questions and answers.

Use to take notes and record data. Leave the notebook holes uncovered and it can be stored in a notebook.

# Sentence Strips

1. Take two sheets of paper (8 1/2" x 11") and fold into hamburgers. Cut along the fold lines making four half sheets. (Use as many half sheets as necessary for additional pages to your book.)
2. Fold each sheet in half like a hot dog.
3. Place the folds side-by-side and staple them together on the left side.
4. 1" from the stapled edge, cut the front page of each folded section up to the mountain top. These cuts form flaps that can be raised and lowered.

To make a half-cover, use a sheet of construction paper one inch longer than the book. Glue the back of the last sheet to the construction paper strip leaving one inch, on the left side, to fold over and cover the original staples. Staple this half-cover in place.

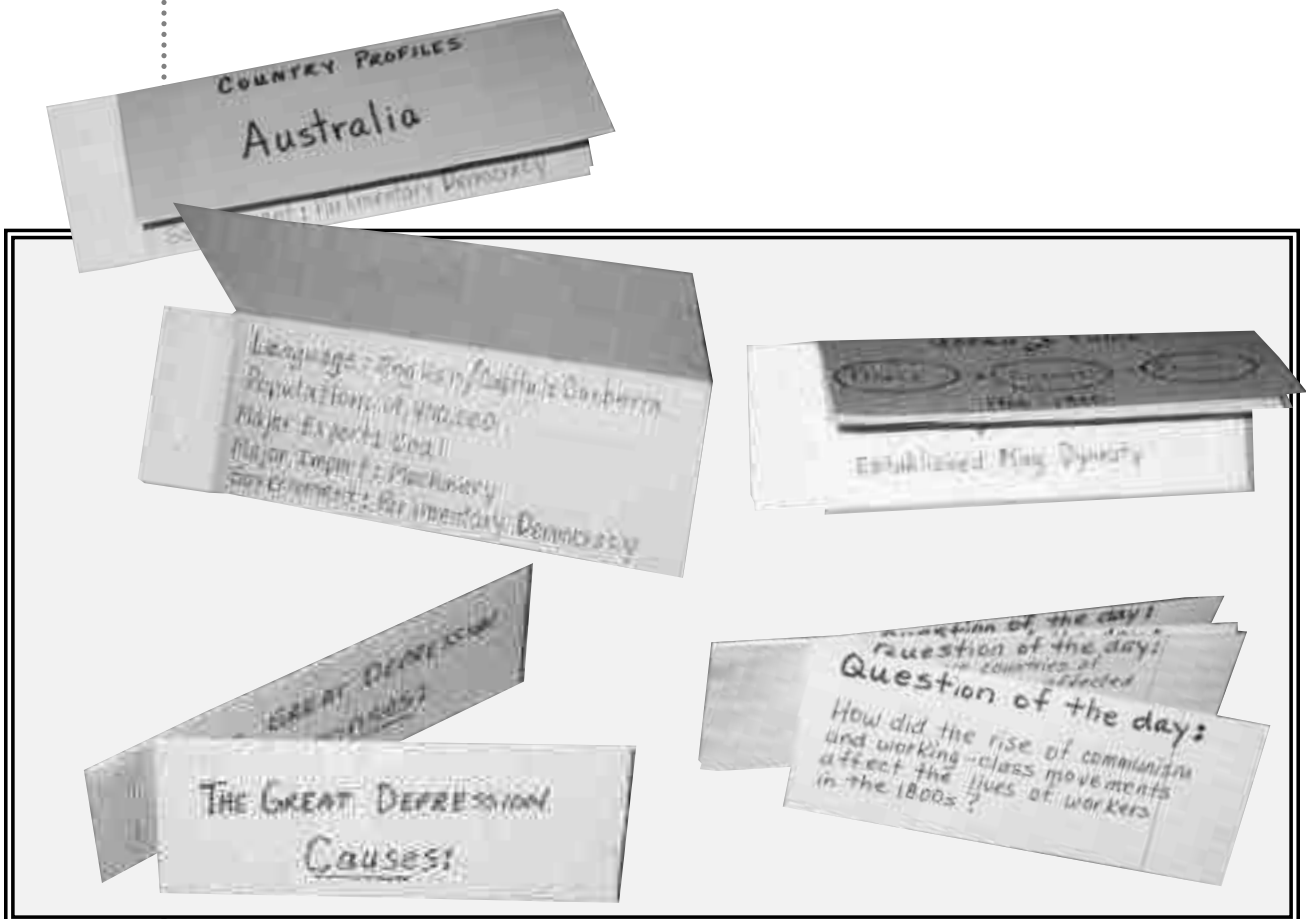
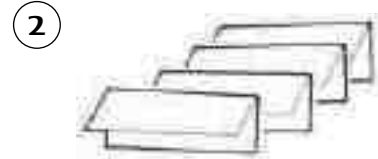

# Sentence-Strip Holder

1. Fold a sheet of paper (8 1/2" x 11") in half like a *hamburger*.
2. Open the *hamburger* and fold the two outer edges toward the *valley*. This forms a *shutter fold*.
3. Fold one of the inside edges of the shutter back to the outside fold. This fold forms a floppy "L."
4. Glue the floppy L-tab down to the base so that it forms a strong, straight L-tab.
5. Glue the other shutter side to the front of this L-tab. This forms a tent that is the backboard for the flashcards or student work to be displayed.
6. Fold the edge of the L-tab up one quarter to one half to form a lip that will keep the student work from slipping off the holder.

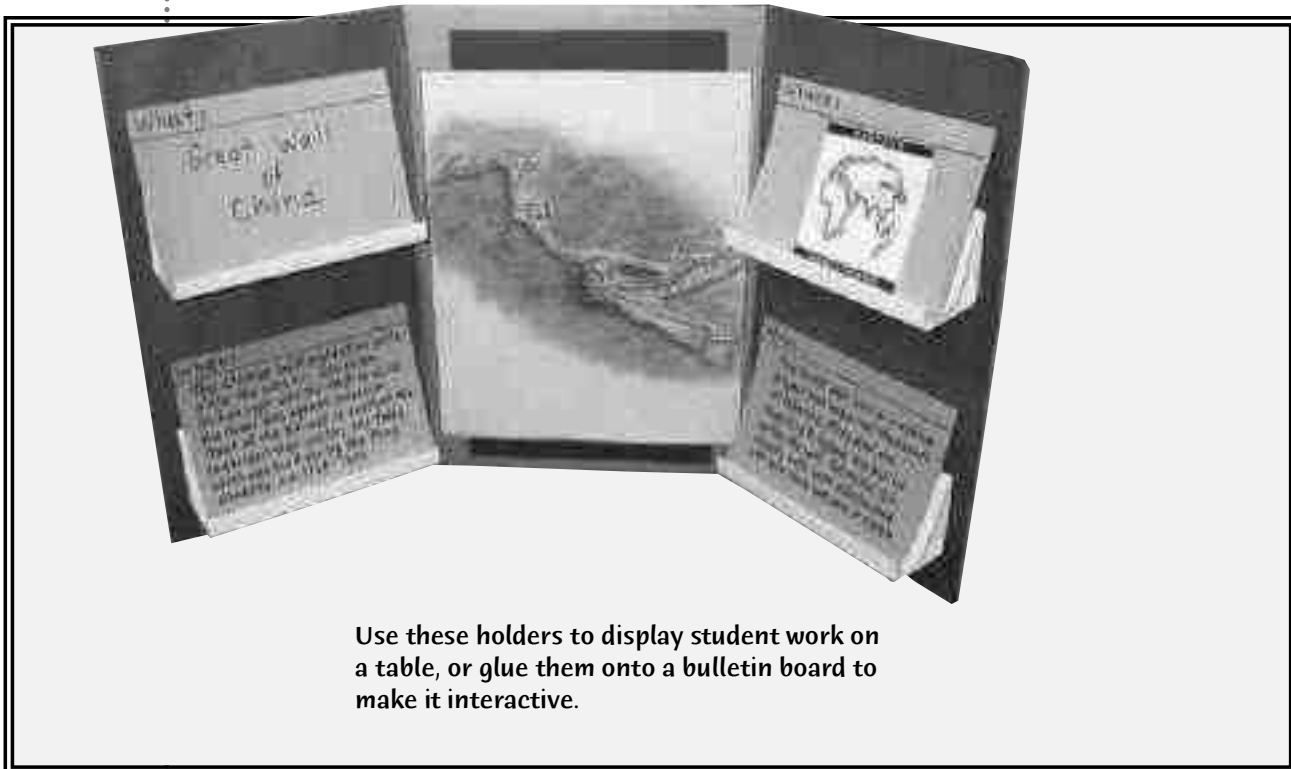
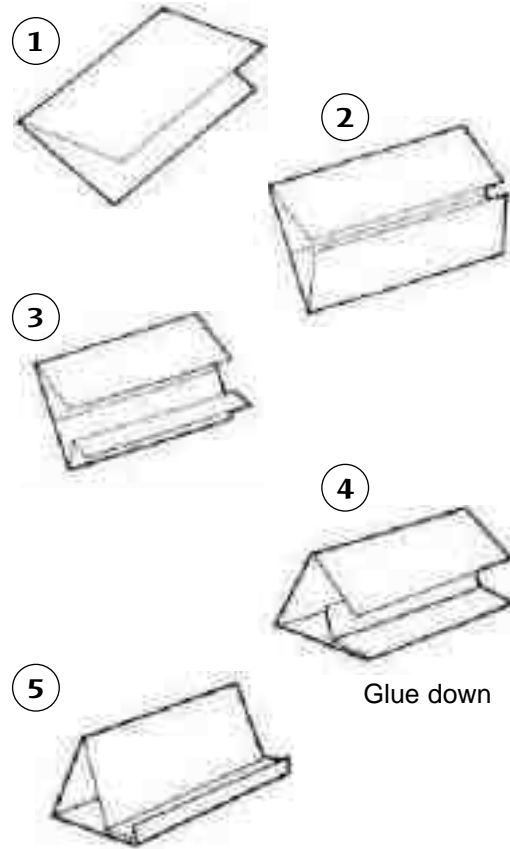

Use these holders to display student work on a table, or glue them onto a bulletin board to make it interactive.

# High School World History

The pages that follow contain Foldable activities to use for key topics in high school world history—from ancient and medieval times to our world today. For teachers’ convenience, the topics are correlated to chapters in *Glencoe World History: Modern Times* and *Glencoe World History*. (See page 42.)

For each topic, there is a summary and three Foldable activities, with instructions and illustrations for students. Students review subject material as they create the Foldables. Students can then use their Foldables to prepare for classroom and standardized tests.

- |                 |  |                 |   |
|-----------------|--|-----------------|---|
| <b>Topic 1</b>  | Early Humans and the Rise of Civilization  | <b>Topic 16</b> | The East Asian World, 1400–1800                 |
| <b>Topic 2</b>  | Mesopotamian and Egyptian Civilizations    | <b>Topic 17</b> | Revolution and Enlightenment                    |
| <b>Topic 3</b>  | Early India and China                      | <b>Topic 18</b> | French Revolution and Napoleon                  |
| <b>Topic 4</b>  | Ancient Greece                             | <b>Topic 19</b> | Industrialization and Nationalism               |
| <b>Topic 5</b>  | Rome and the Rise of Christianity          | <b>Topic 20</b> | Mass Society and Democracy                      |
| <b>Topic 6</b>  | The World of Islam                         | <b>Topic 21</b> | The Height of Imperialism, 1800–1914            |
| <b>Topic 7</b>  | Early African Civilizations                | <b>Topic 22</b> | East Asia Under Challenge                       |
| <b>Topic 8</b>  | The Asian World 400–1500                   | <b>Topic 23</b> | War and Revolution, 1914–1919                   |
| <b>Topic 9</b>  | Emerging Europe and the Byzantine Empire   | <b>Topic 24</b> | The West Between the Wars                       |
| <b>Topic 10</b> | Medieval Europe                            | <b>Topic 25</b> | Nationalism Around the World                    |
| <b>Topic 11</b> | The Americas, 400–1500                     | <b>Topic 26</b> | World War II                                    |
| <b>Topic 12</b> | Renaissance and Reformation, 1350–1600     | <b>Topic 27</b> | Cold War and Postwar Changes                    |
| <b>Topic 13</b> | The Age of Exploration, 1500–1800          | <b>Topic 28</b> | Contemporary Western World, 1970 to the Present |
| <b>Topic 14</b> | Crisis and Absolutism in Europe, 1550–1715 | <b>Topic 29</b> | Latin America, 1945 to the Present              |
| <b>Topic 15</b> | The Muslim Empires, 1450–1800              | <b>Topic 30</b> | Africa and the Middle East, 1945 to the Present |
|                 |  | <b>Topic 31</b> | Asia and the Pacific, 1945 to the Present       |
|                 |  | <b>Topic 32</b> | Challenges and Hopes for the Future             |

# Correlation to Glencoe World History Textbooks

<b>FOLDABLES TOPIC</b>	<b>GLENCOE WORLD HISTORY: MODERN TIMES</b>	<b>GLENCOE WORLD HISTORY:</b>
Early Humans and the Rise of Civilization	Chapter 1	Chapter 1
Mesopotamian and Egyptian Civilizations	Chapter 1	Chapter 2
Early India and China	Chapter 1	Chapter 3
Ancient Greece	Chapter 2	Chapter 4
Rome and the Rise of Christianity	Chapter 2	Chapter 5
The World of Islam	Chapter 3	Chapter 6
Early African Civilizations	Chapter 3	Chapter 7
The Asian World 400–1500	Chapter 3	Chapter 8
Emerging Europe and the Byzantine Empire	Chapter 3	Chapter 9
Medieval Europe	Chapter 4	Chapter 10
The Americas, 400–1500	Chapter 4	Chapter 11
Renaissance and Reformation, 1350–1600	Chapter 5	Chapter 12
The Age of Exploration, 1500–1800	Chapter 6	Chapter 13
Crisis and Absolutism in Europe, 1550–1715	Chapter 7	Chapter 14
The Muslim Empires, 1450–1800	Chapter 8	Chapter 15
The East Asian World, 1400–1800	Chapter 9	Chapter 16
Revolution and Enlightenment	Chapter 10	Chapter 17
French Revolution and Napoleon	Chapter 11	Chapter 18
Industrialization and Nationalism	Chapter 12	Chapter 19
Mass Society and Democracy	Chapter 13	Chapter 20
The Height of Imperialism, 1800–1914	Chapter 14	Chapter 21
East Asia Under Challenge	Chapter 15	Chapter 22
War and Revolution, 1914–1919	Chapter 16	Chapter 23
The West Between the Wars	Chapter 17	Chapter 24
Nationalism Around the World	Chapter 18	Chapter 25
World War II	Chapter 19	Chapter 26
Cold War and Postwar Changes	Chapter 20	Chapter 27
Contemporary Western World, 1970 to the Present	Chapter 21	Chapter 28
Latin America, 1945 to the Present	Chapter 22	Chapter 29
Africa and the Middle East, 1945 to the Present	Chapter 23	Chapter 30
Asia and the Pacific, 1945 to the Present	Chapter 24	Chapter 31
Challenges and Hopes for the Future	Chapter 25	Chapter 32

# Early Humans and the Rise of Civilization

## TOPIC SUMMARY

Archaeologists have found significant evidence that helps them develop theories of how the earliest humans developed. Their research indicates the ways that early humans adapted to their environment. The use of fire, development of agriculture, and domestication of animals mark some of the significant accomplishments of early humans. Human societies grew and developed. As these societies became more complex, civilizations arose.

### Comparing and Contrasting

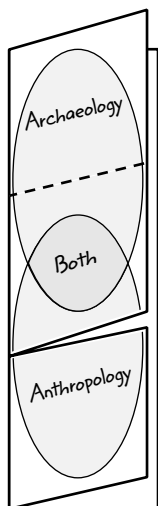

#### Three-Tab Book

Have students prepare a Three-Tab Foldable to compare and contrast archaeology and anthropology. Students should review the text material on these two areas of study. Overlap can be detected in some parts of their studies of the past.

**Materials Needed:** one sheet of 8.5" x 11" paper and scissors

### Sequencing

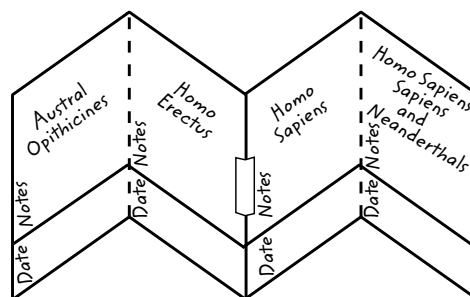

#### Accordion Book

Students can create a usable time line by using an Accordion Book Foldable. Have students insert the names and time periods in which various early humans lived. They can add details to help them remember important characteristics of each of these groups.

**Materials Needed:** two sheets of 8.5" x 11" paper, scissors, and glue

### Analyzing Systematic Agriculture

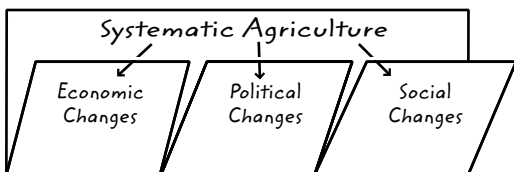

#### Concept-Map Book

Have students analyze the economic, political, and social changes that occurred when humans began using systematic agriculture by creating a Concept-Map Book. Students should review the text on the topic and list as many changes as they can on the inside of the Foldable.

**Materials Needed:** one sheet of 8.5" x 11" paper and scissors

# Mesopotamian and Egyptian Civilizations

## TOPIC SUMMARY

The Sumerians and Mesopotamians built the first civilizations. The Egyptian civilization, benefiting from the Nile River, developed and prospered over many centuries. Nomadic and trading peoples spread ideas throughout Southwest Asia. The Israelites' belief in one God distinguished them from the people groups around them. Empire builders, such as the Assyrians and Persians, conquered vast territories and took over independent states and people groups.

### Describing

Describe:	Location	Religion	Government/ Rulers
Mesopotamia			
Egypt			

#### **Folded Table**

Students can examine two early civilizations—Mesopotamia and Egypt—by creating a Folded Table. In each column students should write phrases that describe the location, religion, and government and rulers of each civilization. Alternately, students could create a folded table with six columns and add descriptions of the culture and technology of each civilization.

**Materials Needed:** one sheet of 11" x 17" paper

### Organizing

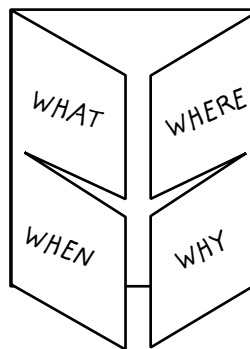

#### **Four-Door Book**

Ask students to read the text related to the Code of Hammurabi and to do additional research about the code. Then have students organize their information by listing facts about the code in a Four-Door Book under the headings *What*, *Where*, *When*, and *Why*.

**Materials Needed:** one sheet of 8.5" x 11" paper and scissors

### Summarizing



#### **Layered-Look Book**

Students should create a Layered-Look Book to help them review the history of ancient Egypt. Students can use each layer to summarize the most important facts about each era of ancient Egypt: the Old Kingdom, from about 2700 to 2200 B.C.; the Middle Kingdom, from about 2050 to 1652 B.C.; and the New Kingdom, from about 1652 to 1085 B.C.

**Materials Needed:** two sheets of 8.5" x 11" paper, stapler or glue



# Early India and China

## TOPIC SUMMARY

Early civilizations in India and China developed social structures and governments to deal with their large populations. Buddhism, Hinduism, Confucianism, Daoism, and Legalism affected the way of life of these civilizations. Trading relationships developed between India, China, and the Roman Empire as goods moved back and forth along the Silk Road and other trading routes.

### Summarizing

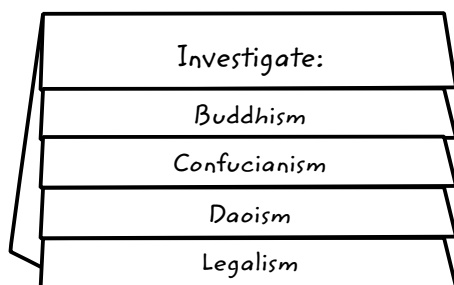

#### Layered-Look Book

Students should create a Layered-Look Book to help them investigate the religions of early India—Hinduism and Buddhism—and the philosophies of early China—Confucianism, Daoism, and Legalism. On each layer students should summarize the history, principles, and beliefs of the religion or philosophy. Students should use information from the text and may do additional research to clarify points or add information to the Foldable.

**Materials Needed:** three sheets of 8.5" x 11" paper, stapler or glue

### Analyzing Causes

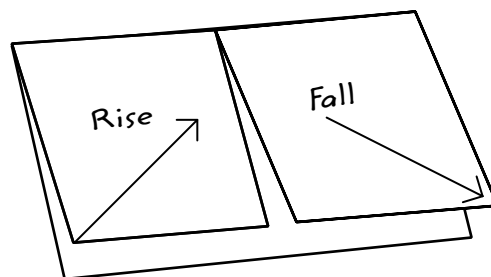

#### Two-Tab Book

Have students create a Two-Tab Book with one section labeled *Rise* and the other labeled *Fall*. Have students select one of the Chinese dynasties—the Shang, Zhou, Qin, Han—to examine. Ask students to record the causes of the dynasty's rise and fall, along with related facts that help explain those causes.

**Materials Needed:** one sheet of 8.5" x 11" paper and scissors

### Organizing

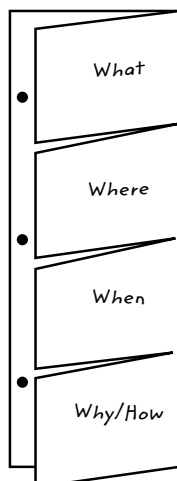

#### Four-Tab Book

Students can create a Four-Tab Book to help them review important facts about either the Great Wall of China or the Silk Road. Students should read the text and conduct additional research about either the Silk Road or the Great Wall. Then they can organize the information by listing facts under the headings *What*, *Where*, *When*, and *Why/How*.

**Materials Needed:** one sheet of 8.5" x 11" paper and scissors

# Ancient Greece

## TOPIC SUMMARY

Greek civilization left a lasting impact on the world. Its example of citizen participation continues to influence government structures around the world today. Arts and culture flourished in ancient Greece, and the foundation of Western philosophy rests on Greek thinkers such as Socrates, Plato, and Aristotle. After uniting the Greek city-states, Alexander the Great conquered the Persian Empire and ushered in the Hellenistic Era.

### Describing

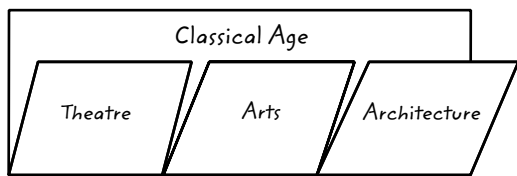

#### 📌 Concept-Map Book

Students create a Concept-Map Book to describe the development of theater, arts, and architecture in the Classical Age. Have students conduct research and add examples of one of these art forms to their Foldable.

**Materials Needed:** one sheet of 8.5" x 11" paper and scissors

### Identifying

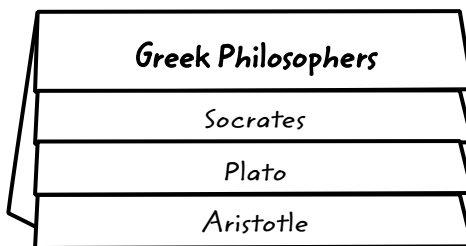

#### 📌 Layered-Look Book

Have students make this Layered-Look Book to help them identify important facts about the life and ideas of three Greek philosophers who lived during the Classical Age—Socrates, Plato, and Aristotle. Have students conduct research to find a meaningful quote from each of the philosophers and add the quotes to the appropriate layer.

**Materials Needed:** two sheets of 8.5" x 11" paper and a stapler or glue

### Organizing

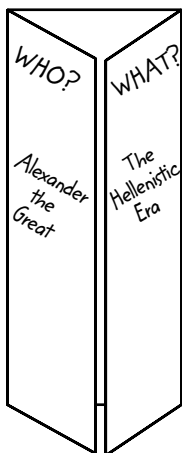

#### 📌 Shutter Fold

Alexander the Great ushered in the Hellenistic Era and spread Greek ideas, language, and culture to Southwest Asia. Have students review the related text material on the Hellenistic Era and create a Shutter Fold to organize facts about this influential period in history.

**Materials Needed:** one sheet of 11" x 17" paper

# Rome and the Rise of Christianity

## TOPIC SUMMARY

Rome established a republic and conquered vast areas of land. Its government was eventually controlled by a small number of powerful leaders. Finally, the republic gave way to a series of emperors who exercised varying degrees of control over the empire. During relatively long periods of peace, Roman arts and culture flourished. Christianity also grew and spread throughout the Western world during this period. Corruption and threats from outside eventually caused the empire to collapse.

### Analyzing Cause and Effect

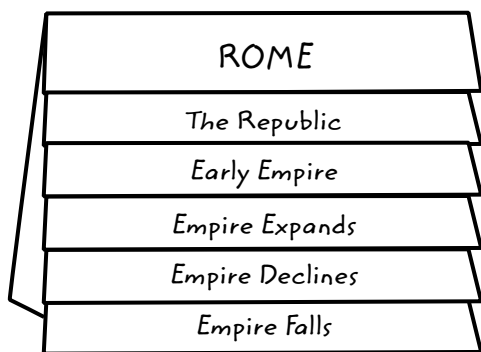

#### Layered-Look Book

Students can organize the events related to the Roman Empire in a Layered-Look Book. Students should review the related text material and list significant events, in sequential order, of the Republic, the early empire, the expanding empire, the declining empire, and the fall of the empire. Students can review the information to examine the causes and effects on the empire of events and leader's decisions.

**Materials Needed:** three sheets of 8.5" x 11" paper and a stapler or glue

### Classifying

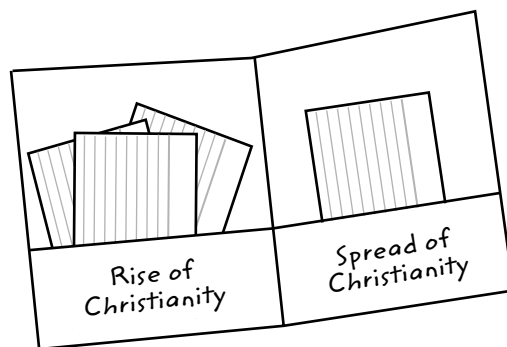

#### Two-Pocket Book

Christianity began during the Roman era and eventually spread throughout the Empire. Have students create a Two-Pocket Book to examine the rise and spread of Christianity. Students should review the text and write facts about events, people, and places on quarter sheets of notebook paper. Have students classify each fact and place it in the appropriate pocket of the book.

**Materials Needed:** one sheet of 8.5" x 11" paper, scissors, and glue

### Analyzing

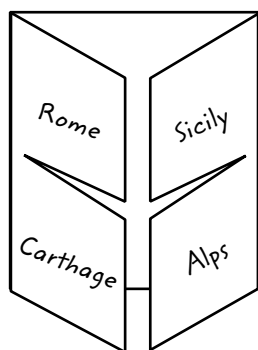

#### Four-Door Book

Have students analyze the impact of geography on Rome's rise by creating a Four-Door Book. Have students sketch a map of Italy and surrounding areas, similar to the map of Italy in their textbooks. Have students label Rome, Sicily, Carthage, and the Alps on the map. On the inside of the book, have students write descriptive phrases that explain the geographic importance of each of these places to Rome's rise.

**Materials Needed:** one sheet of 8.5" x 11" paper and scissors

# The World of Islam

## TOPIC SUMMARY

The religion of Islam was born on the Arabian Peninsula and spread around the world because of the peninsula's location along the caravan trade routes. After Muhammad's death, a prosperous Arab empire was organized, grew, and eventually declined. The Quran, Islam's holy book, guided spiritual, political, economic, and social life. Muslim scholars and artists made significant contributions to the sciences and arts.

### Comparing

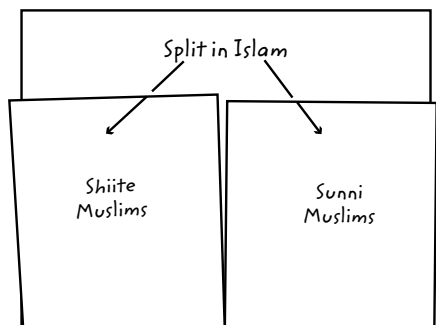

#### 📌 Concept-Map Book

A political disagreement led to a split in Islam. Have students read the related text material and conduct additional research to examine the reasons for the split and the political and religious differences between the two groups. Have students organize this information in a Concept-Map Book with information about each group recorded under the appropriate tab. Have students research the geographic distribution of Shiite and Sunni Muslims in the world today and add this information to the Foldable.

**Materials Needed:** one sheet of 8.5" x 11" paper and scissors

### Analyzing

Philosophy		
Mathematics		
Science		
Medicine		
Art		
Architecture		

#### 📌 Folded Chart

Have students make and use this Folded Chart to write about the advancements made by Muslims in philosophy, mathematics, science, medicine, art, and architecture. Students should include names, places, and dates on the chart.

**Materials Needed:** one sheet of 11" x 17" paper

### Describing

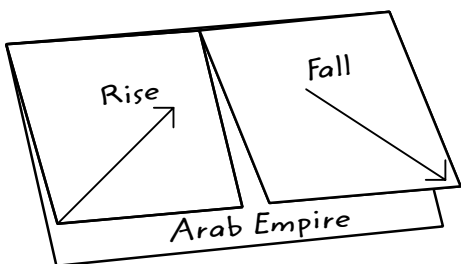

#### 📌 Two-Tab Book

Have students create a Two-Tab Book with one section labeled *Rise* and the other labeled *Fall*. Have students examine the events, people, and places related to the rise and fall of the Arab Empire. Have students review the facts they have written under each tab, and then write a summary on the front of each tab that briefly explains the rise and fall of the empire.

**Materials Needed:** one sheet of 8.5" x 11" paper and scissors

# Early African Civilizations

## TOPIC SUMMARY

Climate zones on the African continent influenced the development and survival of civilizations. Early civilizations grew as the people mastered agricultural techniques. The expansion of trade led to the development of several important kingdoms. Few African societies had a written language. Our knowledge of them comes from records of visitors or from archaeological evidence. African religions varied from the monotheistic to the polytheistic. As in many early civilizations, most art forms, including sculpture, dance, and music, served a religious purpose.

### Explaining

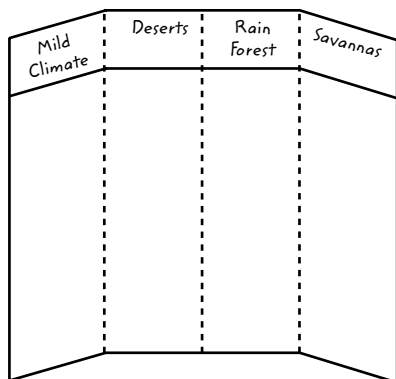

#### **Folded Chart**

Students should explain how the four climate zones affected the development of civilizations in Africa by organizing the information into a Folded Chart.

**Materials Needed:** one sheet of 8.5" x 11" paper

### Comparing and Contrasting

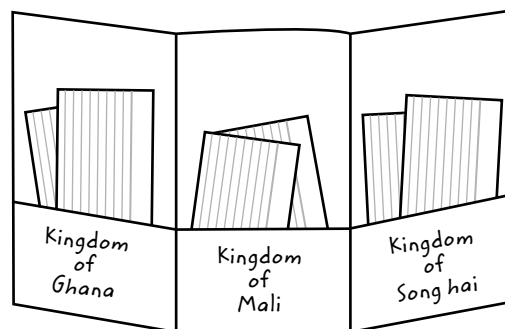

#### **Three-Pocket Book**

Have students make a Three-Pocket Book. Then have them record notes about people, places, and events of the kingdoms of Ghana, Mali, and Songhai on individual quarter sheets of notebook paper. Students should organize the notes in the appropriate pocket.

**Materials Needed:** one sheet of 11" x 17" paper, scissors, and glue

### Identifying

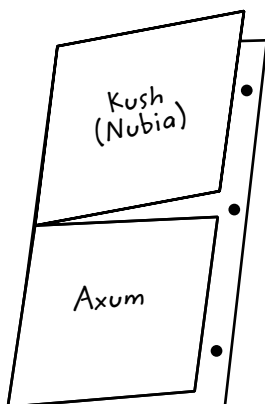

#### **Two-Tab Book**

Have students create a Two-Tab Book to identify facts about the location, culture, and economy of Kush (Nubia) from about 2000 B.C. to 600 B.C. and Axum from about 250 B.C. to A.D. 150. Have students work in pairs to quiz each other about the facts identified. Encourage students to add facts as they are working together.

**Materials Needed:** one sheet of 8.5" x 11" paper and scissors

# The Asian World 400-1500

## TOPIC SUMMARY

During the period between 400 and 1500, China was reunited, trade routes were revived, technology advanced, and agricultural production increased. Japan, isolated by geography, created a unique and largely closed culture. Islam expanded into India. In that country, Hinduism was the strongest religious and social influence, but Islam and Buddhism also played important roles. In Southeast Asia, geography and cultural differences caused several states to develop.

### Summarizing Dynasties

China Reunited	Contributions to Chinese Civilizations	Rulers
Sui Dynasty		
Tang Dynasty		
Song Dynasty		

#### 📌 Folded Table

After a period of about 300 years of chaos and civil war, new dynasties appeared to control China. Have students review the related text and create a Folded Table to summarize information about the rulers and contributions of three Chinese dynasties—the Sui, Tang, and Song.

**Materials Needed:** one sheet of 11" x 17" paper

### Identifying Information

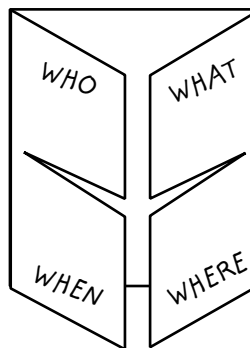

#### 📖 Four-Door Book

Have students select one of the leaders of the Mongol Empire—Kublai Khan or Genghis Khan. First ask students to review the related text and conduct research to learn more about this leader. Then have them create a Four-Door Book to organize the information under the headings *Who*, *What*, *When*, and *Where*.

**Materials Needed:** one sheet of 8.5" x 11" paper and scissors

### Organizing Information

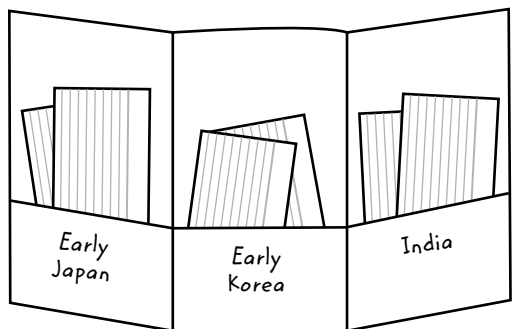

#### 📁 Three-Pocket Book

Have students make this Three-Pocket Book, with a pocket for early Japan, early Korea, and India. Then have students review the related text, writing notes about terms, key locations, people, and events for each. Have students organize the notes by sorting them into the appropriate pockets.

**Materials Needed:** one sheet of 11" x 17" paper, scissors, and glue

# Emerging Europe and the Byzantine Empire

## TOPIC SUMMARY

The European civilization of the Middle Ages was influenced by Germanic peoples, the legacy of the Roman Empire, and Christianity. Charlemagne expanded his reach, creating the Carolingian Empire. Later, various invaders and the collapse of central authority resulted in feudalism. Powerful new rulers consolidated their power and brought an end to the feudal system. In the eastern Mediterranean region, the Byzantine Empire grew and flourished.

### Describing

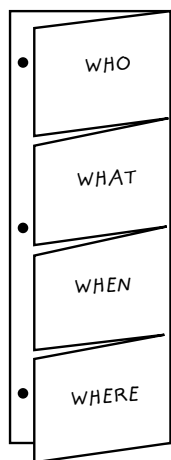

#### 📖 Four-Tab Book

Charlemagne was a powerful Christian ruler. After reading the related text, have students make and use this Four-Tab Book to organize information describing him under the categories of *Who*, *What*, *When*, and *Where*. Have students draw or copy a sculpture or picture of Charlemagne to include with the *Who* tab.

**Materials Needed:** one sheet of 8.5" x 11" paper and scissors

### Summarizing

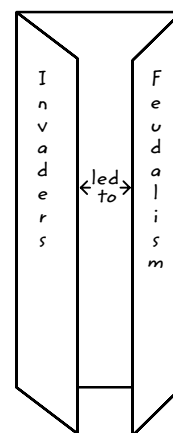

#### 📖 Shutter Fold

Have students create a Shutter Fold Foldable to summarize the actions of the Viking and Visigoth invaders, and how their actions led to feudalism. Inside each fold, create a bulleted list of important facts. For the invaders fold, focus on people, events, and places during the 800s and 900s. For the feudalism fold, focus on causes and social structure.

**Materials Needed:** one sheet of 8.5" x 11" paper

### Identifying

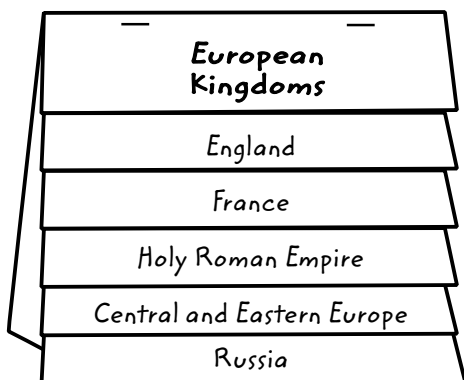

#### 📖 Layered-Look Book

Students can create this Layered-Look Book to identify facts about European kingdoms during High Middle Ages. Have students read the related text and conduct additional research to identify important people, events, and government institutions of England, France, the Holy Roman Empire, Central and Eastern Europe, and Russia.

**Materials Needed:** three sheets of 8.5" x 11" paper and a stapler or glue

# Medieval Europe

## TOPIC SUMMARY

European society flourished as a result of new farming practices, increased trade, and the development of a money economy. The Catholic Church played a dominant role in medieval European society and culture. Gothic cathedrals, built using new technologies, were among the greatest artistic achievements of the period.

### Drawing Conclusions

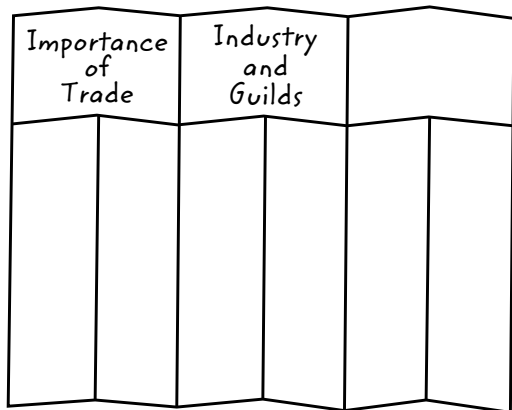

#### 📄 Folded Chart

During the eleventh and twelfth centuries, trade and industry replaced Europe's economic reliance on agriculture. Have students read the related text and create a Folded Chart to examine why and how trade became important and how industry and guilds developed.

**Materials Needed:** one sheet of 8.5" x 11" paper

### Comparing and Contrasting

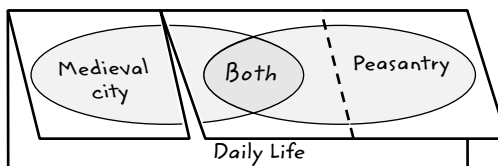

#### 📖 Three-Tab Book

Students can make and use this Three-Tab Book to create a Venn diagram to help them compare daily life in medieval cities with daily life of the peasantry. Have students focus on such topics as type of labor, diet, housing, and other living conditions of each group.

**Materials Needed:** one sheet of 8.5" x 11" paper and scissors

### Identifying Cause and Effect

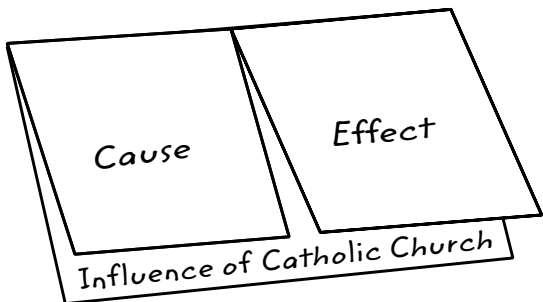

#### 📖 Two-Tab Book

Have students create a Two-Tab Book to describe cause-and-effect relationships related to the influence of the Catholic Church in Medieval Europe. Have students select events from the 1000s, 1100s, and 1200s. For each event, have students identify two or more causes and effects.

**Materials Needed:** one sheet of 8.5" x 11" paper and scissors



# The Americas, 400-1500

## TOPIC SUMMARY

Early inhabitants of the Americas were hunter-gatherers. Several distinct cultures, which had adapted to different geography and climates, arose. The Mayan, Aztec, and Incan civilizations developed distinct political, religious, and social structures. The Mayan civilization declined for reasons that are still unclear. Spanish conquests brought an end to both the Aztec and Incan civilizations.

### Comparing

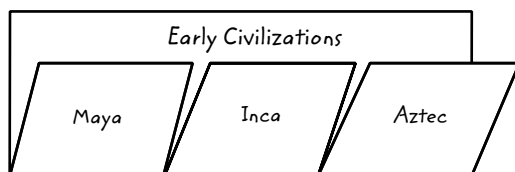

#### 📌 Concept-Map Book

Students can make and use this Concept-Map Book to help them compare the Mayan, Aztec, and Incan civilizations. Have students include statements about the political, religious, and social structures of the three civilizations.

**Materials Needed:** one sheet of 8.5" x 11" paper and scissors

### Describing

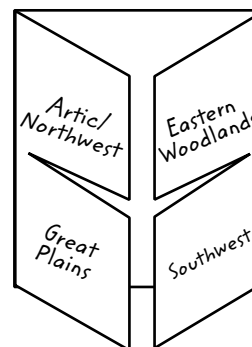

#### 📌 Four-Door Book

Have students create this Four-Door Book to examine the influence of geography and climate on the first inhabitants of the Americas. Students should read the related text and write statements under tabs for the Arctic/Northwest, the Eastern Woodlands, the Great Plains, and the Southwest.

**Materials Needed:** one sheet of 11" x 17" paper and scissors

### Organizing

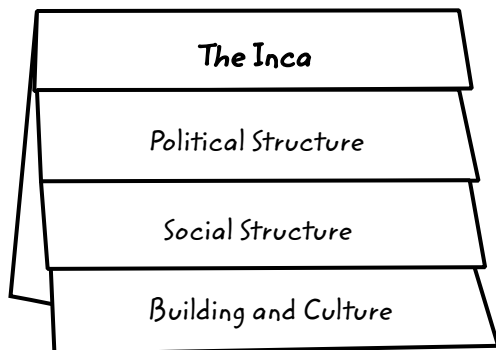

#### 📌 Layered-Look Book

Students can create this Layered-Look Book to organize facts about the Inca. Have students read the related text and conduct research to learn more about the political structure, social structure, and buildings and culture of the Inca.

**Materials Needed:** two sheets of 8.5" x 11" paper and a stapler or glue

# Renaissance and Reformation, 1350-1600

## TOPIC SUMMARY

The Renaissance describes a new age of human achievement in the arts and sciences. At the same time, religious reformers, such as Martin Luther, sought to reform the Catholic Church. Their ideas and actions brought about the Protestant Reformation. Different forms of Protestantism arose throughout Europe, and the Catholic Church responded with renewed vigor.

### Identifying

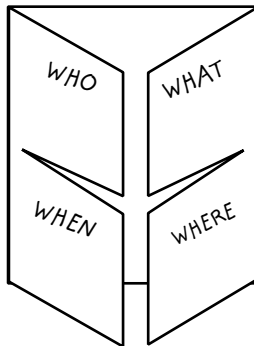

#### 📖 Four-Door Book

Have students make and use this Four-Door Book to explore the Protestant Reformation. As students read the related text, have them record dates, events, places, and ideas under the tabs labeled *Who*, *What*, *When*, and *Where*. Encourage students to add facts about other leaders of the Protestant Reformation, noting their names on the front of the Foldable.

**Materials Needed:** one sheet of 8.5" x 11" paper and scissors

### Sequencing

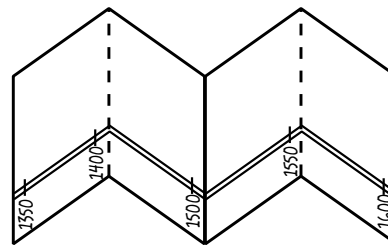

#### 📖 Accordion Book

Students can create a usable time line by using an Accordion Book Foldable. Have students read the related text and create a time line of the significant events, people, places, and ideas of the Renaissance and Reformation using this Foldable. Have students conduct additional research and add four entries to the time line for each period of time.

**Materials Needed:** one sheet of 11" x 17" paper

### Analyzing

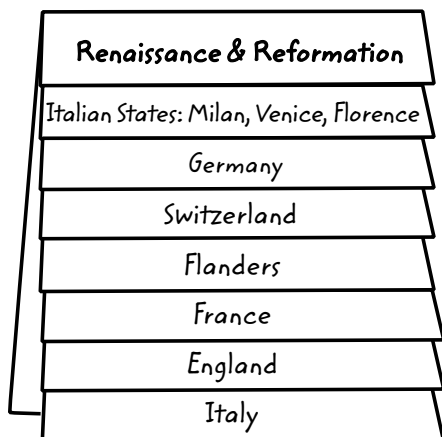

#### 📖 Layered-Look Book

Have students create this Layered-Look Book to analyze how the Renaissance and Reformation affected various parts of Europe. Students should include the effects of the Renaissance and Reformation on the Italian states (Milan, Venice, and Florence), Germany, Switzerland, Flanders, France, England, and Italy. Students should label each of their effects as *Renaissance* or *Reformation*.

**Materials Needed:** four sheets of 8.5" x 11" paper and a stapler or glue

# The Age of Exploration, 1500-1800

## TOPIC SUMMARY

During the age of European exploration, nations sought to gain territory, goods, or trading partners. Explorers risked long voyages over unfamiliar oceans and seas to gain an economic advantage. During this period, the international trade in enslaved Africans began. In the next three centuries, millions of Africans were enslaved and sent abroad. Millions were sent to the New World—the Caribbean, Brazil, and the American South mostly—to work on sugar, coffee, tobacco, rice, and cotton plantations.

### Describing

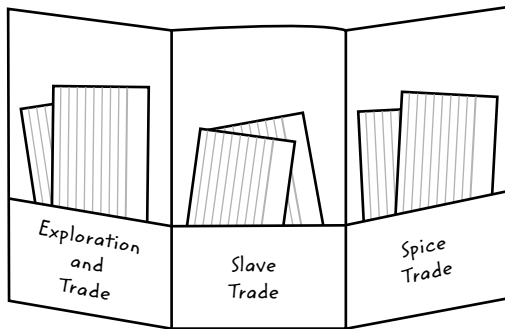

#### Three-Pocket Book

Have students make this Three-Pocket Book to organize information about exploration and trade, slave trade, and spice trade from 1500 to 1800. Students should take notes as they read the related material on quarter sheets of notebook paper. Students should review their notes and place them in the appropriate pocket.

**Materials Needed:** one sheet of 11" x 17" paper, scissors, and glue

### Identifying

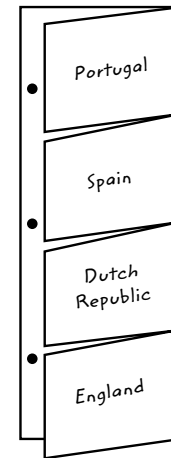

#### Four-Tab Book

Have students make this Four-Tab Book to record information about the explorations of the Portuguese, Spanish, Dutch, and English. Have students focus on people, places, dates, items traded, and rivalries with other nations.

**Materials Needed:** one sheet of 8.5" x 11" paper and scissors

### Categorizing

Compare	Date	Country	Discovery
Explorer #1			
Explorer #2			
Explorer #3			

#### Folded Table

Have students create this Folded Table to categorize information about any three explorers discussed in the chapter on the Age of Exploration. Information should be categorized by date, country, and discovery. Encourage students to conduct additional research about these explorers and add facts discovered to the Foldable.

**Materials Needed:** one sheet of 11" x 17" paper

# Crisis and Absolutism in Europe, 1550-1715

## TOPIC SUMMARY

The monarchs who ruled England, France, Spain, the German states, and Russia from 1550 to 1750 battled to expand their domain and their power. Their struggles led to ongoing strife. Protestants and Catholics also fought for political and religious control. Literature and the arts flourished in parts of Europe, while political thinkers wrestled with ideas about the purpose and scope of government.

### Organizing

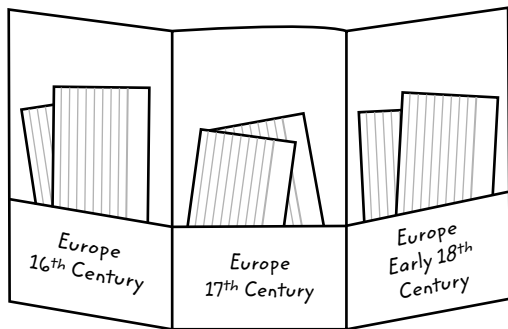

#### Three-Pocket Folder

Have students make this Three-Pocket Book to organize information about Europe in the 16th, 17th, and 18th centuries. Students should take notes on quarter sheets of notebook paper about important events, people, and places as they read the chapter. Have them organize their papers by placing them in the appropriate pocket.

**Materials Needed:** one sheet of 11" x 17" paper, scissors, and glue

### Analyzing Points of View

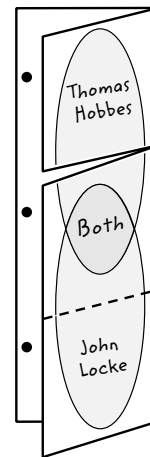

#### Three-Tab Book

Have students make and use this Three-Tab Book to create a Venn diagram analyzing the points of view of two English political thinkers—Thomas Hobbes and John Locke. Students should write things the two men had in common in the overlapping area of the ovals. Then they can write the highlights of their different approaches to the political climate of the 1600s in the distinct areas of the ovals.

**Materials Needed:** one sheet of 8.5" x 11" paper and scissors

### Organizing



#### Layered-Look Book

Have students make and use this Layered-Look Book to organize information as they read the chapter. Students should write important dates, people, places, and events on flaps labeled *The Wars of Religion*; *Social Crises, War, Revolution*; and *Absolutism*.

**Materials Needed:** two sheets of 8.5" x 11" paper and a stapler or glue

# The Muslim Empires, 1450-1800

## TOPIC SUMMARY

During this period, powerful empires controlled most of Asia and Southwest Asia. Each succeeding empire reached further to bring more people and territory under its control. Politically, these empires had strong central authority and brought new levels of technical and military efficiency to their states. Culturally, the arts and literature flourished as the region became known for its silk weaving, carpet weaving, architecture, and mosaics.

### Categorizing

Muslim Empires	Key Events and Rulers	Religion and Art	Society and Culture
Ottoman Empire			
Safavid Empire			
Mogul Empire			

#### 📄 Folded Table

Students can create this Folded Table to help them categorize information about the three Muslim empires: Ottoman, Safavid, and Mogul. Categories to explore include key events and rulers, religion and art, and society and culture.

**Materials Needed:** one sheet of 8.5" x 11" paper

### Comparing and Contrasting

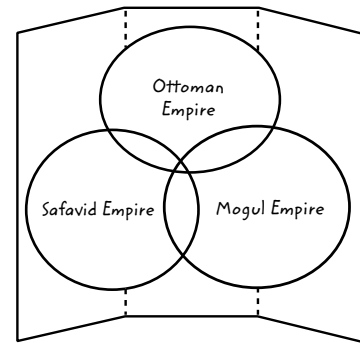

#### 📄 Trifold Book

Have students make a Trifold Book to compare and contrast the three Muslim empires: Ottoman, Safavid, and Mogul. Since there are three ovals that overlap in this Venn diagram, students will need to be careful to place information in the appropriate areas. Remind students that the areas where two ovals overlap indicate items that both empires have in common, while the area where all three overlap means the item applies to all three empires.

**Materials Needed:** one sheet of 8.5" x 11" paper

### Describing

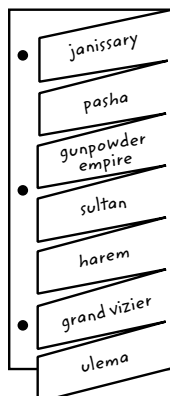

#### 📄 Vocabulary Book

Have students make a Vocabulary Book to record key terms in each section of the chapter related to the Muslim Empires. On the inside of each tab, students should write a complete definition of the term.

**Materials Needed:** one sheet of 8.5" x 11" paper and scissors

# The East Asian World, 1400-1800

## TOPIC SUMMARY

Sophisticated cultures and civilizations developed in China, Japan, and Korea between 1400 and 1800. To varying degrees, all three cultures sought to keep Europeans away and to resist the influence of Western ideas and culture. Each civilization developed unique traditions. Tensions existed between the ruling class and the peasant population in China and Japan. Korea was located between China and Japan, but it managed to withstand invasions from both.

### Comparing and Contrasting

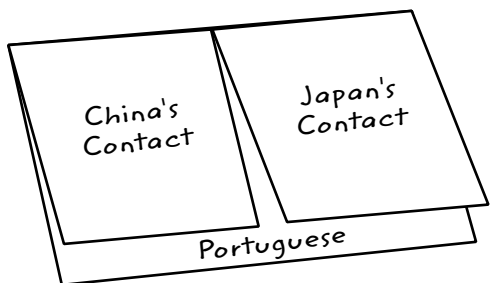

#### Two-Tab Book

Have students make and use this Two-Tab Book to explore the experiences of the Chinese and Japanese as they came into contact with the Portuguese. Under each tab, students should write dates, important people, and how these are connected to Western influence on China and Japan.

**Materials Needed:** one sheet of 8.5" x 11" paper and scissors

### Sequencing

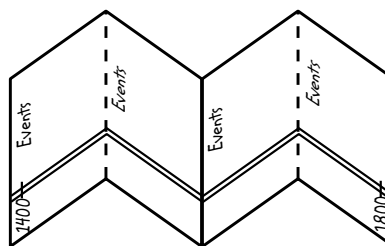

#### Accordion Book

Students can make and use this Accordion Book to create a time line of the key events in the history of the East Asian world from 1400 to 1800. Have students include events listed in the related reading and conduct research to add at least four other important events.

**Materials Needed:** one sheet of 11" x 17" paper

### Identifying

Investigate	Society	Politics
Tokugawa Japan		
Yi Dynasty Korea		

#### Folded Table

Have students investigate the society and politics of the Tokugawa in Japan and the Yi Dynasty in Korea using a Folded Table. Have students use their text and additional research as sources of information.

**Materials Needed:** one sheet of 11" x 17" paper

# Revolution and Enlightenment

## TOPIC SUMMARY

During the Scientific Revolution in Europe in the 1500s and 1600s, new ideas in the sciences and philosophy changed the way Europeans viewed the physical world and their place in it. New theories, based on the scientific method and human reason, replaced old beliefs. The Enlightenment of the 1700s used the ideas of the Scientific Revolution to examine many areas of life, including economics, education, religion, and the arts.

### Describing

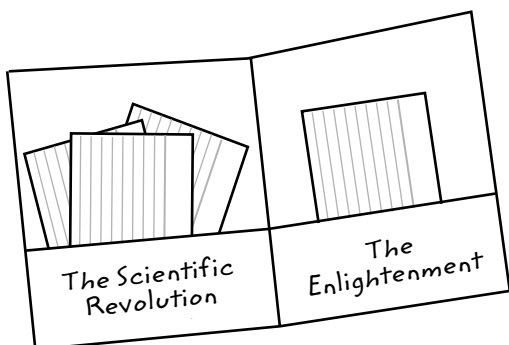

#### Two-Pocket Book

Have students record notes about important terms, people, places, and ideas related to the Scientific Revolution and the Enlightenment on quarter sheets. Then have students place the notes in the appropriate pocket of the Foldable.

**Materials Needed:** one sheet of 8.5" x 11" paper, scissors, and glue

### Organizing

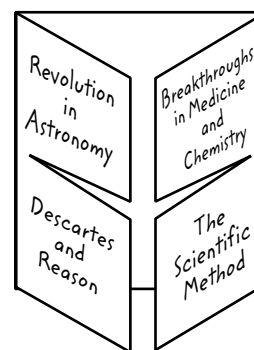

#### Four-Door Book

Have students make and use this Four-Door Book to organize information about the Scientific Revolution. Students should write significant facts about the revolution in astronomy, breakthroughs in medicine and chemistry, Descartes and reason, and the scientific method under the appropriate flap.

**Materials Needed:** one sheet of 8.5" x 11" paper and scissors

### Describing

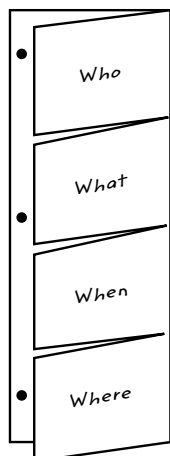

#### Four-Tab Book

Have students create this Four-Tab Book, using *Who*, *What*, *When*, and *Where*, to describe the life and work of one of the three French philosophers of the Enlightenment—Montesquieu, Voltaire, or Diderot.

**Materials Needed:** one sheet of 8.5" x 11" paper and scissors

# French Revolution and Napoleon

## TOPIC SUMMARY

In 1789, the oppression of the Third Estate and Enlightenment ideals led to the French Revolution. During its most radical phase, known as the Reign of Terror, the French were also fighting against the kings of Europe who wanted to restore the French king. Under Napoleon, the French defeated foreign armies and for awhile Napoleon had an empire. Although Napoleon was defeated at Waterloo, the French Revolution had made all citizens equal under the law.

### Identifying

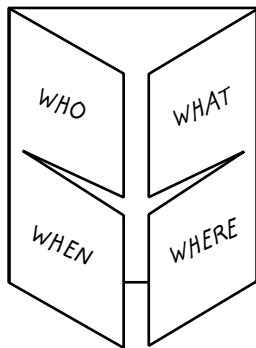

#### Four-Door Book

Have students create a Four-Door Book to record *Who*, *What*, *When*, and *Where* facts while they are reading about Napoleon Bonaparte. Encourage students to conduct additional research to add facts, illustrations, or maps to their Foldable.

**Materials Needed:** one sheet of 11" x 17" paper and scissors

### Identifying Cause-and-Effect

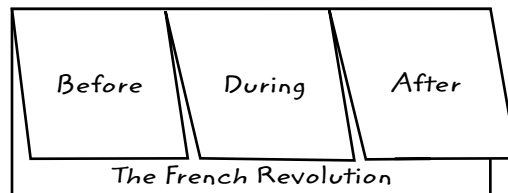

#### Three-Tab Book

Have students create this Three-Tab Book to examine important events in France before, during, and after either the Reign of Terror or the French Revolution.

**Materials Needed:** one sheet of 8.5" x 11" paper and scissors

### Comparing and Contrasting

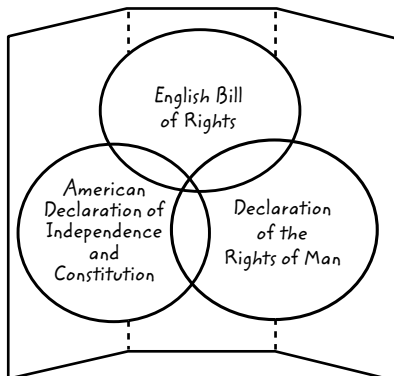

#### Trifold Book

Have students use this Trifold Book to create a Venn diagram to explore the similarities and differences among the English Bill of Rights, the American Declaration of Independence, and the Declaration of the Rights of Man. Students should describe where each document was created, when each document was created, and who influenced the document's creation.

**Materials Needed:** one sheet of 8.5" x 11" paper



# Industrialization and Nationalism

## TOPIC SUMMARY

The Industrial Revolution dramatically changed Europe and North America as they moved from agricultural economies to industrial economies. Cities grew around the new industries as people moved to live near the factories. The political philosophies of conservatism, nationalism, and liberalism vied for dominance. Culturally, romanticism and realism were the prevailing movements of the time.

### Analyzing Changes

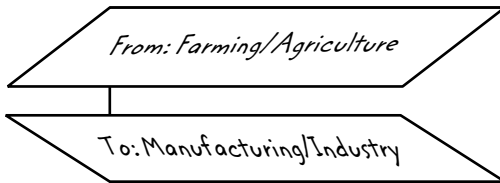

#### Shutter Fold

Have students create a Shutter Fold to analyze the changes that occurred during the Industrial Revolution as economies moved from farming/agriculture to manufacturing/industry. Have students make a bulleted list under each fold that describes the economy and society of an agricultural and an industrial community.

**Materials Needed:** one sheet of 8.5" x 11" paper

### Describing

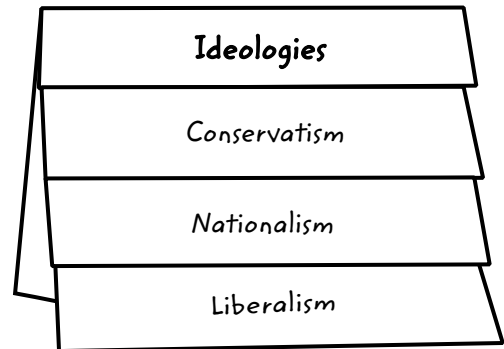

#### Layered-Look Book

Have students create a Layered-Look Book with flaps for the prevailing ideologies during the 1800s. Students should record notes about conservatism, nationalism, and liberalism under the appropriate flap. Notes should focus on definitions and important concepts of each.

**Materials Needed:** two sheets of 8.5" x 11" paper and a stapler or glue

### Analyzing

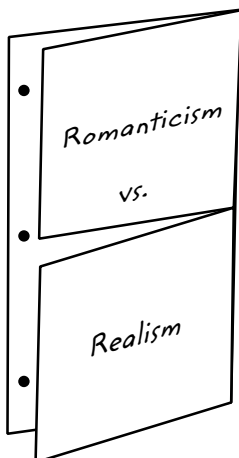

#### Two-Tab Book

Have students create a Two-Tab Book to compare and contrast romanticism and realism. As they read the related text material, have students take notes on how each influenced life in the 1800s. Have students conduct research to find a work of literature or art that represents each idea and add the name of the work to their Foldable.

**Materials Needed:** one sheet of 8.5" x 11" paper and scissors

# Mass Society and Democracy

## TOPIC SUMMARY

The period from 1850 to 1914 marked a major shift in how people thought about science, economics, and art. Technological change profoundly affected the way people lived. Increased wages improved the standard-of-living for many industrial workers and expanded the middle class. Women enjoyed new opportunities in education and employment, though they still lacked a political voice. International rivalries led to the Balkans crises and World War I.

### Organizing

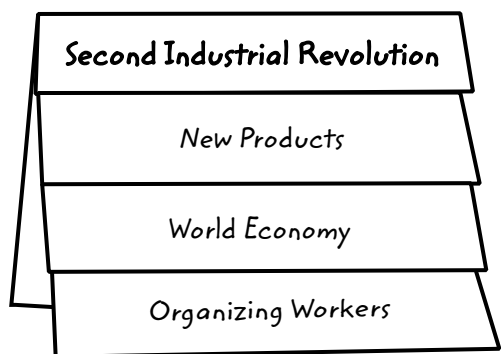

#### Layered-Look Book

Students can create a Layered-Look Book to organize facts about the new products, world economy, and worker organization during the second Industrial Revolution. Have students create a second Layered-Look Book that explores the same topics related to the technology revolution of the 1900s and 2000s.

**Materials Needed:** two sheets of 8.5" x 11" paper and a stapler or glue

### Comparing Opportunities

Second Industrial Revolution	Before Revolution	After Revolution
Job Opportunities for Women		
Marriage and Family		
Women's Rights		

#### Folded Table

Have students use this Folded Table to examine the lives of women before and after the second Industrial Revolution. Students should consider the following categories in their comparisons: job opportunities for women, marriage and women's role in family life, and women's rights.

**Materials Needed:** one sheet of 11" x 17" paper

### Identifying

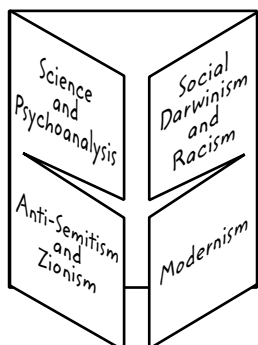

#### Four-Door Book

Ask students to make a Four-Door Book to examine the social and scientific movements of the late 1800s and early 1900s. As students read related text, they should list definitions, important people, and key ideas related to science and psychoanalysis, Social Darwinism and racism, anti-Semitism and Zionism, and modernism. Students may conduct research about one or more of the movements to add information to the Foldable.

**Materials Needed:** one sheet of 11" x 17" paper and scissors

# The Height of Imperialism, 1800-1914

## TOPIC SUMMARY

During this period, major European countries and the United States controlled much of Asia, Africa, and Latin America. Colonial rule benefited the colonial powers much more than any colony. Export policies exploited the workforce and natural resources of the colonies. National leaders such as Miguel Hidalgo and Simón Bolívar led movements to gain independence from imperial rule.

### Describing

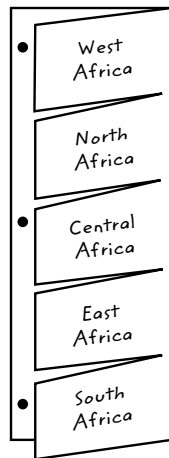

#### Five-Tab Book

Students can make this Five-Tab Book to describe imperialism in West Africa, North Africa, Central Africa, East Africa, and South Africa. As students read the related text material, they should make notes under each tab naming the colonial rulers and the natural resources exported from the colonies.

**Materials Needed:** one sheet of 8.5" x 11" paper and scissors

### Sequencing

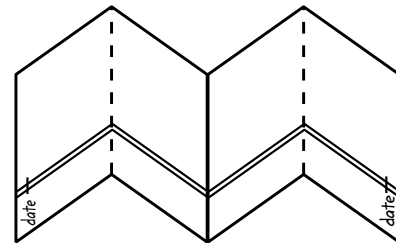

#### Accordion Book

Have students make a time line of the key events related to the British rule of India using an Accordion Book. As students read the related text, they should record key events at the appropriate point on the time line. Have students conduct research to add information to the time line.

**Materials Needed:** one sheet of 11" x 17" paper

### Comparing and Contrasting

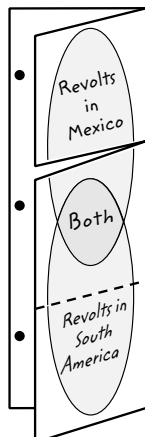

#### Three-Tab Book

Ask students to create a Venn diagram using a Three-Tab Book to make a close comparison of the revolts in Mexico and South America. The overlapping area of the ovals should include characteristics that both revolts had in common.

**Materials Needed:** one sheet of 8.5" x 11" paper and scissors

# East Asia Under Challenge

## TOPIC SUMMARY

Great struggles occurred in China and Japan between 1800 and 1914. In both countries, the conflicts resulted from contact with the West and from internal conditions, such as weak economies. A series of events in China and Japan pushed each country to armed conflict. These struggles eventually led to dramatic changes in government, economy, and culture. During the period, both Asian powers opened their doors to the West.

### Describing

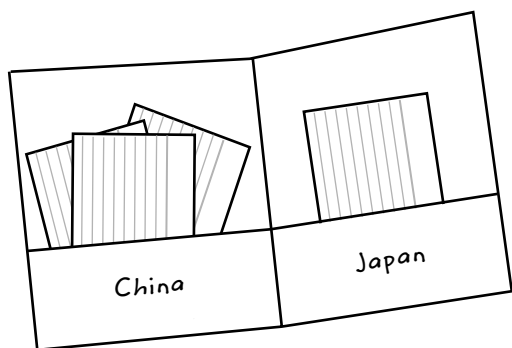

#### Two-Pocket Book

As students read the related text, have them record notes about terms, key events, people, and places in China and Japan on quarter sheets of notebook paper. Students should place the notes in the appropriate pocket of the Two-Pocket Book. Have students add a map of each country at the top of their Two-Pocket Books.

**Materials Needed:** one sheet of 8.5" x 11" paper, scissors, and a stapler or glue

### Identifying Cause-and-Effect

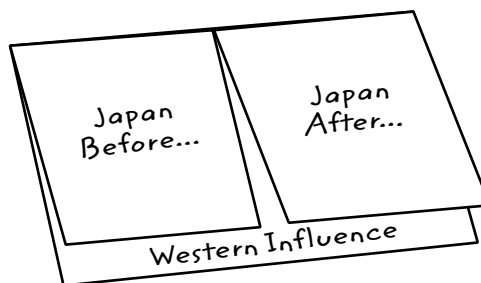

#### Two-Tab Book

Have students create this Two-Tab Book to compare Japan before and after Western influence. As students read the related text and conduct research, they should record aspects of daily life, women's roles, politics, and economics that existed before and after Western influence in Japan.

**Materials Needed:** one sheet of 8.5" x 11" paper and scissors

### Identifying

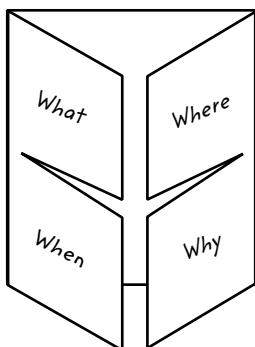

#### Four-Door Book

Ask students to create a Four-Door Book to identify *What*, *Where*, *When*, and *Why* facts about the Boxer Rebellion. As students read the related text and conduct research, they should add statements under the appropriate flap to examine this Chinese uprising in 1900 and the response to it.

**Materials Needed:** one sheet of 8.5" x 11" paper and scissors

# War and Revolution, 1914-1919

## TOPIC SUMMARY

The carnage of World War I was unlike anything the world had previously experienced. Thousands died during this war of attrition. Airplanes and airships were used for the first time in battle. When the war ended, the peace settlement required the defeated countries to pay heavy reparations to the victors. The resentment and anger caused by these reparations led to World War II.

### Organizing

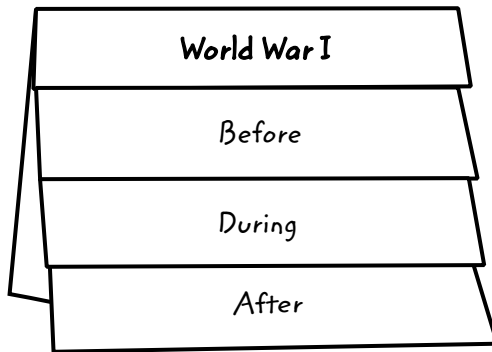

#### Layered-Look Book

Have students make a Layered-Look Book to organize the important events, places, and people before, during, and after World War I. Encourage students to conduct research and add information to each layer of the book.

**Materials Needed:** two sheets of 8.5" x 11" paper and a stapler or glue

### Sequencing

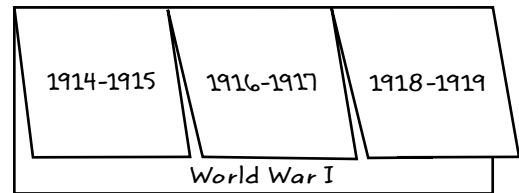

#### Three-Tab Book

Students can make and use this Three-Tab Book to sequence events that occurred during World War I. Have students list facts related to 1914–1915, 1916–1917, and 1918–1919. Facts should focus on key leaders, places, and important turning points of each period of the war.

**Materials Needed:** one sheet of 8.5" x 11" paper and scissors

### Analyzing



#### Two-Tab Book

Students should read the text material related to the Russian Revolution. To organize their reading, ask students to make and use a Two-Tab Book. Under one tab, they should record the political, social, and economic events that led up to the revolution. Under the other tab, they should record the political and military events that brought the communists to power.

**Materials Needed:** one sheet of 8.5" x 11" paper and scissors

# The West Between the Wars

## TOPIC SUMMARY

After the war, many countries struggled under the strain of war debts and a world wide economic depression. Totalitarian governments emerged in Germany, Italy, and the Soviet Union. Radio and movies, both popular forms of entertainment, also began to be used to communicate political messages. Art movements such as Dadaism and surrealism reflected a new mood in society. People no longer felt that the world was rational.

### Identifying Cause and Effect

<ul style="list-style-type: none"> <li>The Great Depression</li> </ul>	
Causes	Responses
<ul style="list-style-type: none"> <li></li> <li></li> </ul>	

#### 📄 Folded Chart

Have students make and use this Folded Chart to examine the causes and effects of the Great Depression. Students should list the causes of the Great Depression in the left column. Across from each cause, students should list one or more responses from individuals, society as a whole, or the government.

**Materials Needed:** one sheet of 8.5" x 11" paper

### Comparing and Contrasting

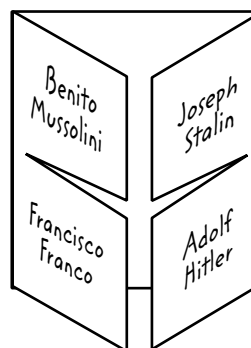

#### 📖 Four-Door Book

Have students create a Four-Door Book to compare and contrast the dictatorships of Benito Mussolini, Josef Stalin, Francisco Franco, and Adolph Hitler. Have students list facts about each ruler under the appropriate flap. This Foldable will be a helpful study guide on the differences and similarities of these four men.

**Materials Needed:** one sheet of 11" x 17" paper and scissors

### Analyzing Policies

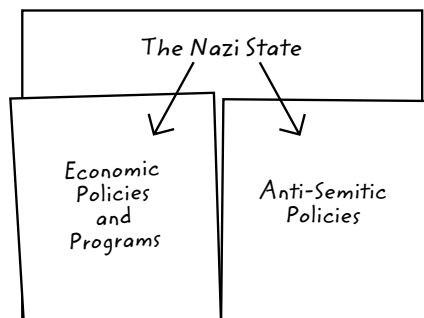

#### 📄 Two-Tab Concept Map

To explore the policies of the Nazi state, have students make and use this Two-Tab Concept Map. Students should record facts about the economic policies and programs of the Nazi state, including what brought the Nazis to power, under one flap. Under the other flap, students should write facts related to the Nazis' anti-Semitic policies and the actions taken as a result.

**Materials Needed:** one sheet of 8.5" x 11" paper and scissors

# Nationalism Around the World

## TOPIC SUMMARY

Around the globe, people struggled to break traditional power structures after the end of World War I. In Asia, the Ottoman Empire crumbled. The Nationalist forces of Chiang Kai-shek struggled against the Communist forces of Mao Zedong. Militarism grew in Japan, as it sought to dominate Asia. Africans and Latin Americans sought to break colonial ties and form new nations.

### Organizing

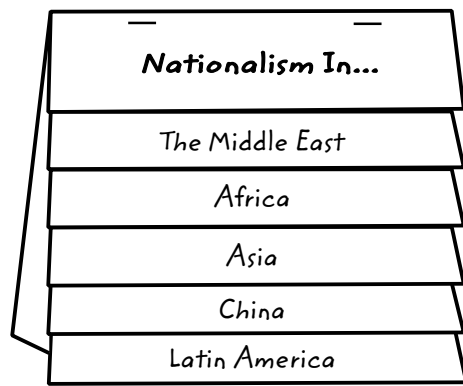

#### Layered-Look Book

Have students make this Layered-Look Book to list the ways that nationalism took shape in the Middle East, Africa, Asia, China, and Latin America. Have students add information to each flap that explores the countries that were formed and that gained their independence. Facts should focus on the people and groups who led the independence movements, what they sought, and what they accomplished.

**Materials Needed:** three sheets of 8.5" x 11" paper and a stapler or glue

### Drawing Conclusions

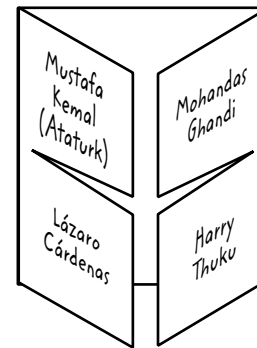

#### Four-Door Book

Ask students to write notes in this Four-Door Book about four leaders of nationalist movements: Mustafa Kemal, Mohandas Gandhi, Lázaro Cárdenas, and Harry Thuku. Based on this information, students can draw conclusions about what each leader sought to accomplish and what they ultimately achieved.

**Materials Needed:** one sheet of 11" x 17" paper and scissors

### Describing

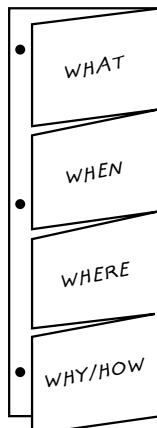

#### Four-Tab Book

Have students describe the *What*, *When*, *Where*, and *Why/How* related to the Balfour Declaration in a Four-Tab Book. As students read the related text and conduct research, have them record information in the four categories. This Foldable will help them understand how this declaration changed the Middle East and created upheaval that has yet to be resolved.

**Materials Needed:** one sheet of 8.5" x 11" paper and scissors

# World War II

## TOPIC SUMMARY

The actions and ambitions of Germany and Japan paved the way for another major war. Germany's invasion of Poland in 1939 ignited war in Europe. The United States was drawn into the war in 1941 when the Japanese attacked Pearl Harbor, Hawaii. The United States, Great Britain, France, and the Soviet Union (the Allied powers) fought Germany, Italy, and Japan (the Axis powers). In 1945, the Axis powers were defeated.

### Identifying

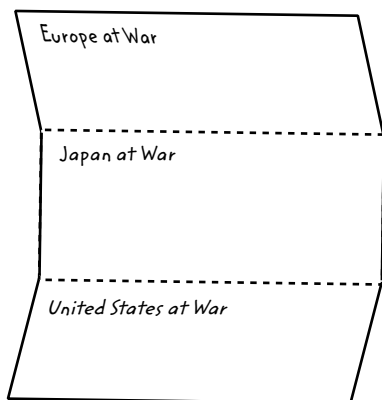

#### Trifold Book

Ask students to make and use this Trifold Book to write facts about Europe, Japan, and the United States during World War II. Students should focus on significant battles and their results. Have students conduct research to add information to the Foldable, including information about significant military and political leaders during the war.

**Materials Needed:** one sheet of 8.5" x 11" paper

### Analyzing Causes

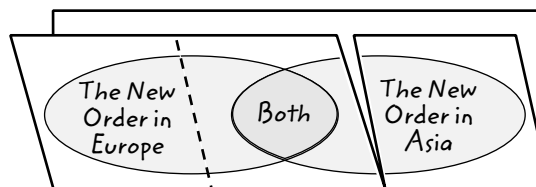

#### Three-Tab Book

Have students create a Three-Tab Book to compare the paths that Germany and Japan took to war. Students should list the factors that contributed to war-like governments in Germany and Japan. Factors that are found in both Germany and Japan should be listed in the overlapping space of the Venn diagram.

**Materials Needed:** one sheet of 8.5" x 11" paper and scissors

### Explaining

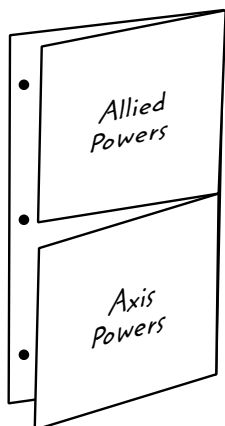

#### Two-Tab Book

Have students create this Two-Tab Book to examine the effects World War II had on the victors and on the defeated. As students read the related text and conduct research, have them write notes about the effects of World War II on the United States, Britain, and the Soviet Union (the Allied powers) under one tab and on Germany, Italy, and Japan (the Axis powers) under the other.

**Materials Needed:** one sheet of 8.5" x 11" paper and scissors



# Cold War and Postwar Changes

## TOPIC SUMMARY

Recovery from the massive destruction caused by World War II required a new level of international cooperation. At the same time, differences between the Soviet Union and the United States after World War II led them to compete for dominance in a global struggle known as the Cold War. In subsequent decades, rapid social changes and technological developments resulted in many economic and social changes in Western society.

### Identifying Cause and Effect

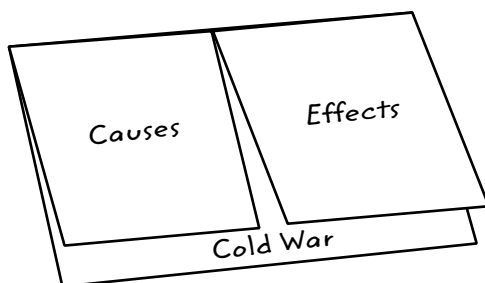

#### Two-Tab Book

As students read the text, have them create and use this Two-Tab Book to list the causes and effects of the Cold War. For each cause that students list, tell them to identify two or more effects. Have students list these in the Foldable in a way that they can easily identify the effects that resulted from each cause.

**Materials Needed:** one sheet of 8.5" x 11" paper and scissors

### Drawing Conclusions

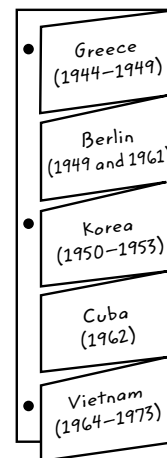

#### Five-Tab Book

Have students create a Five-Tab Book to identify the key events of the Cold War. As they read the related text, students should list events that took place in Greece in 1944–1949, Berlin in 1949 and 1961, Korea in 1950–1953, Cuba in 1962, and Vietnam in 1964–1973. From the events students list, they may draw conclusions about how the events have affected the world we live in today.

**Materials Needed:** one sheet of 8.5" x 11" paper and scissors

### Organizing Information

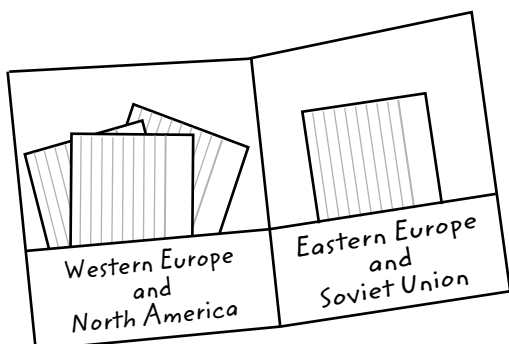

#### Two-Pocket Book

Ask students to record notes about key terms, people, places, and events during the Cold War in Western Europe, North America, Eastern Europe, and the Soviet Union on quarter sheets of paper. Then have students organize the notes, placing them in the appropriate pocket.

**Materials Needed:** one sheet of 8.5" x 11" paper, scissors, and glue

# Contemporary Western World, 1970–Present

## TOPIC SUMMARY

Recent political upheavals have changed the Western world. The Soviet Union broke apart, and many former Soviet states formed democratic governments. Ethnic conflicts in some areas threaten to destabilize governments. The computer and the Internet link the world in ways never before possible. As a result, a global society and global economy are emerging.

### Identifying

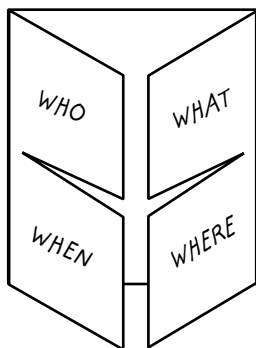

#### Four-Door Book

Ask students to research the historical role played by either Mikhail Gorbachev or Lech Walesa in reshaping the Soviet Union during the 1980s. Have students organize the information using a Four-Door Book with *Who*, *What*, *When*, and *Where* categories.

**Materials Needed:** one sheet of 8.5" x 11" paper and scissors

### Describing

Transitions to Free-Market Economy	
Peaceful	Violent

#### Folded Chart

Ask students to create a Folded Chart to describe places and events related to peaceful and violent transitions to a free-market economy. Have students add a world map to the back of the chart and use two different colors to identify the places where these peaceful and violent transitions occurred.

**Materials Needed:** one sheet of 8.5" x 11" paper

### Drawing Conclusions

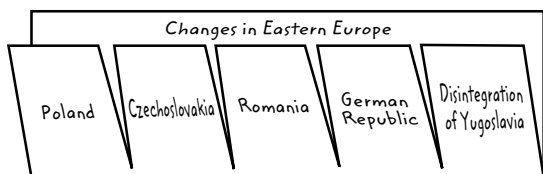

#### Five-Tab Concept-Map Book

Have students create a Five-Tab Concept-Map Book to analyze the changes in Eastern Europe in the 1980s and early 1990s. Have students include facts about who led the transition, whether the transition from communism was peaceful or violent, and what challenges the new governments faced.

**Materials Needed:** one sheet of 8.5" x 11" paper and scissors

# Latin America, 1945 to the Present

## TOPIC SUMMARY

In many Latin American countries, progress toward political and economic stability has been slow. Although some advances have been made, there is still great disparity of wealth, and periodic civil wars and revolution. In the late 1980s, however, a number of countries have turned toward democracy. In fact, the only communist country in Latin America or the entire Western hemisphere is Cuba.

### Summarizing

Latin American Country	Economy	Leaders

#### **Folded Table**

Have students create a Folded Table, listing Latin American nations in the left column. As students read the related text, they should summarize information about each country's economy and leaders since 1945 in the second and third columns.

**Materials Needed:** one sheet of 8.5" x 11" paper

### Describing



#### **Layered-Look Book**

Have students make a Layered-Look Book, writing facts under each tab for Argentina, Brazil, Chile, and Peru. Have students include information about each country's leaders, economic and social challenges, and how these challenges were met.

**Materials Needed:** two sheets of 8.5" x 11" paper and a stapler or glue

### Comparing

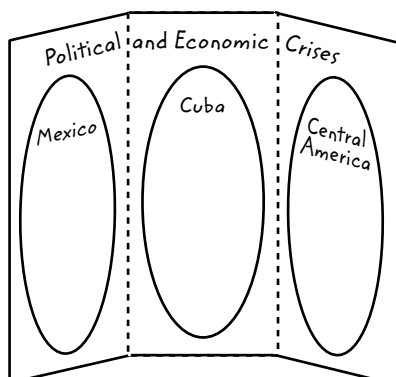

#### **Trifold Book**

Students should create a Trifold Book and write facts about the political and economic crises in Mexico, Cuba, and Central America from 1945 to the present. Have students gather information from their textbooks and by conducting research. Encourage students to include facts about contemporary events in each place.

**Materials Needed:** one sheet of 8.5" x 11" paper

# Africa and the Middle East, 1945 to the Present

## TOPIC SUMMARY

During the 1950s, 1960s, and 1970s most African nations gained their independence from colonial powers. However, African nations continue to struggle under military or dictatorial regimes. Poverty continues to plague the continent as it seeks its place in the global economy. In the Middle East, nearly every aspect of life—political, social, economic, and cultural—has changed since the end of World War II.

### Analyzing Results

African Nation	Date of Independence	Result

#### 📌 Folded Table

Have students create this Folded Table that lists African nations that gained their independence in the late 1950s and 1960s in the left column. Have students identify the date of each nation’s independence and research the immediate results of the change. Have students write summary statements about the results in the third column.

**Materials Needed:** one sheet of 8.5" x 11" paper

### Analyzing Points of View

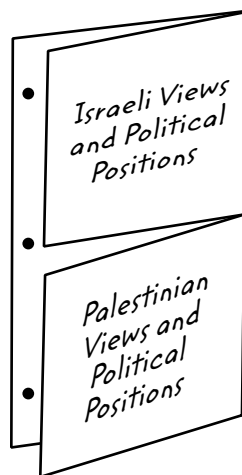

#### 📌 Two-Tab Book

Have students make a Two-Tab Book to compare Israeli views and political positions with Palestinian views and political positions during the 1950s to 1980s. Have students read related text and write summary statements that will help them compare the points of view of each group.

**Materials Needed:** one sheet of 8.5" x 11" paper and scissors

### Describing

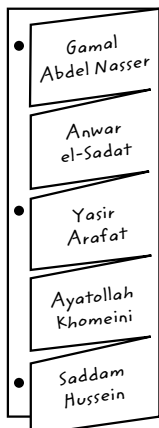

#### 📌 Five-Tab Book

Have students make a Five-Tab Book to list the facts about five different political leaders in the Middle East since 1950: Gamal Nasser, Anwar el-Sadat, Yasir Arafat, Ayatollah Khomeini, and Saddam Hussein. For each leader, have students include information about their political views, especially related to the Arab-Israeli conflict, their style of leadership, and the results of their leadership.

**Materials Needed:** one sheet of 8.5" x 11" paper and scissors

# Asia and the Pacific, 1945 to the Present

## TOPIC SUMMARY

The nations of Asia and the Pacific play an increasingly important role in the world's political, economic, and cultural development. Many of these countries have endured civil wars and struggled with economic difficulties and the poverty of their large populations. Other countries have enjoyed relative stability.

### Drawing Conclusions

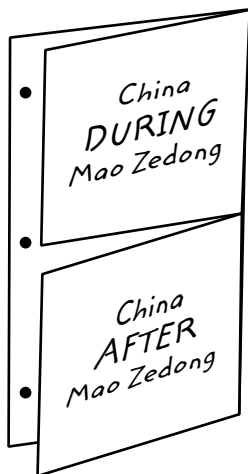

#### Two-Tab Book

Mao Zedong came to power in China in 1949 and controlled China until his death in 1976. Have students create a Two-Tab Book to describe the social, political, and economic climate in China during and after Mao Zedong's rule.

**Materials Needed:** one sheet of 8.5" x 11" paper and scissors

### Sequencing

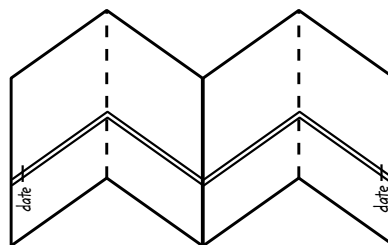

#### Accordion Book

Have students create an Accordion Book to record a time line of the key events in the history of postwar Asia. Encourage students to conduct research and make short annotations for the events on their time lines.

**Materials Needed:** one sheet of 11" x 17" paper

### Describing

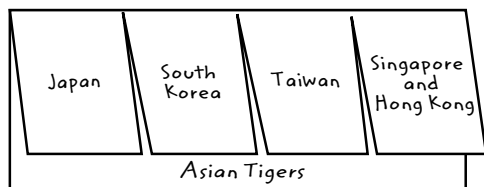

#### Four-Tab Book

Have students make and use a Four-Tab Book to help them review developments in Asia since 1945. On the four tabs, students should list the following: Japan, South Korea, Taiwan, and on the last tab, Singapore and Hong Kong. Under each tab, students should list important leaders, and the most important domestic and international events for that country.

**Materials Needed:** one sheet of 8.5" x 11" paper and scissors

# Challenges and Hopes for the Future

## TOPIC SUMMARY

The technological revolution has created a global economy, but not all nations or people have benefited. Improved communication allows ideas and cultures to be shared worldwide, but today's world faces numerous economic, political, and environmental challenges.

### Identifying

World Challenges			
Environment	Social	Economic	Political

#### ↑ Folded Chart

Have students draw an outline map of the world. Then have them make and use this Folded Chart to identify environmental, social, economic, and political challenges in the world today. Students should summarize information about challenges such as the economic challenge of the gap between rich and poor nations or the environmental challenge of global warming caused by the greenhouse effect.

**Materials Needed:** one sheet of 11" x 17" paper

### Making Predictions

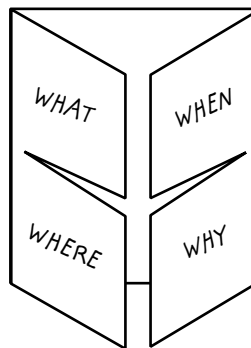

#### ↑ Four-Door Book

Have students make and use a Four-Door Book to organize *What*, *When*, *Where*, and *Why* information about the United Nations. Students should focus on the facts of how and when the organization was created, what specialized organizations are part of the United Nations, and what goals the organization has for its future.

**Materials Needed:** one sheet of 8.5" x 11" paper and scissors

### Summarizing

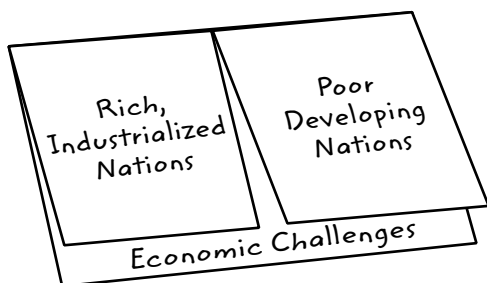

#### ↶ Two-Tab Book

Have students create a Two-Tab Book. As students read the related text and conduct research, they should summarize the current economic challenges facing industrialized nations and developing nations under the appropriate tabs.

**Materials Needed:** one sheet of 8.5" x 11" paper and scissors